

AIR OPERATED PRODUCTION SPOT WELDING GUNS

ITEMS

3321 - 3322

3323

3324 - 3327 - 3328

INSTRUCTION AND INSTALLATION MANUAL

DISTRIBUTOR:

EDITION: 2007

TECNA S.p.A.

Via Grieco 25/27 - 40024 Castel S. Pietro Terme - Bologna ITALY
Pho. +39.051.6954400 - Tel. 051.6954410 - Fax +39.051.6954490
E-Mail:sales@tecna.net - vendite@tecna.net

INDEX

0	INTRODUCTION	5
0.1	PURPOSE OF THE INSTRUCTION MANUAL	5
0.2	KEEPING OF THE INSTRUCTION MANUAL	5
0.3	HOW TO UPDATE THE INSTRUCTION MANUAL	5
1	GENERAL INFORMATION	6
1.1	MANUFACTURER IDENTIFICATION DATA	6
1.2	IDENTIFICATION DATA	6
1.3	INFORMATION ABOUT TECHNICAL ASSISTANCE	6
1.4	GENERAL SAFETY RULES	6
1.5	GLOSSARY AND SYMBOLS ON THE WELDER AND IN THE MANUAL	7
2	INFORMATION ABOUT THE WELDER	9
2.1	DESCRIPTION OF THE WELDER MAIN FEATURES	9
2.2	IDENTIFICATION OF THE WELDER MAIN PARTS	10
2.3	TECHNICAL DATA	12
2.4	FORESEEN USE	13
3	TRANSPORT AND HANDLING	14
3.0	GENERAL INFORMATION	14
3.1	PACKING	14
3.2	TRANSPORT AND HANDLING OF THE PACKED WELDER	14
3.3	STORAGE OF THE WELDER BOTH PACKED AND UNPACKED	14
3.4	UNPACKING	15
3.5	HANDLING OF THE UNPACKED WELDER	15
4	INSTALLATION	16
4.0	GENERAL WARNINGS	16
4.1	REQUIRED ENVIRONMENT CONDITIONS	16
4.2	LOCATION OF THE WELDER	16
4.3	ACCOMPLISHMENT OF THE ASSEMBLY	17
4.4	CONNECTION TO THE ELECTRIC SUPPLY	18
5	WELDER SET UP	20
5.0	GENERAL NOTICE	20
5.1	DESCRIPTION OF THE WELDING CONTROL UNIT	20
5.1.1	BUILT-IN CONTROL UNIT TE300	20
5.1.2	BUILT-IN CONTROL UNIT TE450	21
5.2	ELECTRIC GENERAL SWITCH (Emergency Interruption)	22
5.3	SAFETY RULES	22
5.4	MACHINE FUNCTIONING	23
5.5	RESIDUAL RISKS	25
6	MACHINE USE	26
6.0	GENERAL INFORMATION	26
6.1	CALCULATION OF THE MAXIMUM WELDING RATING	26
6.2	TROUBLESHOOTING	27
6.3	REMEDIES FOR WELDS IMPERFECTIONS	29
7	INSTRUCTIONS FOR THE ADJUSTMENTS	30
7.0	GENERAL INFORMATION	30
7.1	STANDARD ACCESSORIES	30
7.2	MECHANICAL SET UP	30
7.2.1	ARMS SELECTION AND REPLACEMENT	30
7.2.2	SUSPENSION ADJUSTMENT	34
7.2.3	ARMS ADJUSTMENT	36
7.2.4	ELECTRODES ADJUSTMENT	38
7.2.5	WORKING STROKE ADJUSTMENT	40
7.2.6	DOUBLE STROKE USE	42
7.3	ELECTRODE FORCE ADJUSTMENT	43
7.4	WORKING PROGRAM ADJUSTMENT	45

8	MAINTENANCE	46
8.0	GENERAL INFORMATION	46
8.1	ORDINARY MAINTENANCE	46
8.2	EXTRAORDINARY MAINTENANCE	47
8.2.1	LOWERING OF THE WELDING UNIT PERFORMANCES	47
8.2.2	REPAIR OR REPLACEMENT OF THE SUPPLY CABLE	48
9	SUPPLEMENTARY INSTRUCTIONS	50
9.0	GENERAL INFORMATION	50
9.1	WASTE DISPOSAL	50
9.2	OFF DUTY EQUIPMENT AND DISMANTLING	50
9.3	EMERGENCY CONDITIONS INSTRUCTIONS	50
10	ENCLOSURES	51
10.0	GENERAL INFORMATION	51
10.1	ACCESSORIES AND SPARE PARTS REQUEST	51
10.2	WELDING TABLES	54
10.3	TE300 PRODUCTION FORM FACSIMILE	56
10.4	TE450 PRODUCTION FORM FACSIMILE	57

This page intentionally left blank.

0 INTRODUCTION

CAREFULLY READ THIS INSTRUCTION MANUAL BEFORE INSTALLING AND OPERATING THE WELDER.

0.1 PURPOSE OF THE INSTRUCTION MANUAL

This instruction manual is part of the welder and is aimed at providing all the necessary information in order to:

- provide the operators with the proper information concerning safety issues;
- handle the welder, both packed and unpacked, under safety conditions;
- properly install the welder;
- deeply be acquainted with the working of the welder and its limits;
- use properly the welder under safety conditions;
- change type of production and perform maintenance, adequately and safely;
- dismantle the welder under safe conditions and in compliance with the provisions in force about the workers and environment care.



The personnel responsible of each department, in which the welder will be installed, are obliged, according to the laws in force, to carefully read the content of this document and make it available for reading to the personnel who use and maintain the welder, for the parts relevant for them.

The time spent in this activity will be widely saved thanks to a proper working of the welder and its use under safety conditions.

This document is based on the supposition that the safety and sanitary rules in force are applied in the place where the welder will be installed.

The instructions, drawings and the content of this manual have a technical nature and their property is strictly reserved to the manufacturer and cannot be reproduced in any way, neither fully nor partially.

Besides, the customer undertakes the responsibility to check that, in case this document is modified by the manufacturer, only the updated versions of this manual are present where the welder is used.

This welder has been designed for resistance welding of both ferrous and non ferrous (aluminium, brass) materials. The welder must not be used for other applications; i.e. pieces heating, mechanical working carried out by using the electrodes force. The welder has been designed to be used by an operator by using the foreseen control devices. All modifications, even slight ones, are forbidden because they should invalidate the welder CE certification.



The welders described in this manual have been designed to be used only for professional purposes in industrial environments. They must not be installed on public lines at low voltage supplying domestic premises. This can cause electromagnetic interferences.

TECNA S.p.A. is not responsible for any damage to both people, animals, things and to the welder itself caused by a wrong use, or the lack or the superficial observance of the safety warnings stated in this manual, nor it is responsible for damages coming from even slight tampering or from the use of not-suitable spare parts, or of spare parts other than the original ones.

0.2 KEEPING OF THE INSTRUCTION MANUAL

The instruction manual must be kept with care and must always follow the welder in all the changes of property that it could have during its life.

The good keeping must be enhanced by a careful handling, with clean hands and having care not to put it on dirty surfaces.

It is forbidden to take off, tear or to arbitrarily change parts of this instruction manual.

The manual must be stored in a place safe from humidity and heat and close to its relevant welder.

0.3 HOW TO UPDATE THE INSTRUCTION MANUAL

In case of any modification on the welder installed at the customer premises, that have been agreed upon by the manufacturer and that require to change the Instruction Manual, the manufacturer should send the revised Instruction Manual.

The user is responsible for changing the old manual with the new one.

1 GENERAL INFORMATION

1.1 MANUFACTURER IDENTIFICATION DATA

MANUFACTURER

TECNA S.p.A.

HEADQUARTER:

TECNA S.p.A.
Via Grieco, 25/27
40024 Castel San Pietro Terme
Bologna
Italy

Pho. ++39.051.6954400
Fax ++39.051.6954490

e-mail:sales@tecna.net - vendite@tecna.net
http://www.tecna.net

1.2 IDENTIFICATION DATA

ITEM: _____

SERIAL NUMBER: _____

YEAR OF MANUFACTURING: _____

ARMS: _____

CONTROL UNIT: _____

SUPPLY VOLTAGE: _____

CABLES LENGTH: _____

PNEUMATIC GROUP: _____

1.3 INFORMATION ABOUT TECHNICAL ASSISTANCE

The welding machines of the manufacturer are covered by warranty, as per general sales conditions. If, within the validity of the warranty, defective workings of the welder or faults, which are included in the warranty clauses, are detected, the manufacturer will take care of repair or replacement of faulty parts, after his technical evaluation on the welder.

It is reminded that even slight modifications made by the user, without written authorization by the manufacturer, invalidate the warranty and discharge the manufacturer by any responsibility for damages caused by a defective product.

This is valid especially in case above modifications are made on safety devices, invalidating their efficiency.

The same prescriptions are valid when using non original spare parts or spare parts different from the ones explicitly informed by the manufacturer.

For all the above reasons, we suggest to our customers to call our Technical Service for any problem.

1.4 GENERAL SAFETY RULES



Before using the welder it is necessary to carefully read the instructions in this manual and carefully follow its prescriptions.

The manufacturer has designed this welder to be INTRINSICALLY SAFE, as much as possible. The welder has been equipped with all the protections and safety devices which have been deemed necessary, and finally, it is provided with information enough for its safe and correct use.

To this purpose in each chapter, when necessary, for the operator-welder interaction the following information have been provided:

- Minimum operator skills required
- Number of operators required
- Status of the welder
- Remaining dangers
- Necessary or suggested protection devices
- Avoidance of human errors
- Prohibitions/obligations referred to mistaken actions which can be reasonably foreseen.



This information should be carefully followed.

The user can appropriately add information to the ones provided by the manufacturer for example additional working instructions, which of course must not be in contrast to what is stated in this manual, in order to help safe use of the welder.

For example, particular attention must be paid to the clothes worn by anyone working with the welder:

- avoid wearing clothes with holds which could be caught into the welder;
- avoid using ties or flying clothes;
- avoid wearing large rings or armlets which could get the hands caught by the welder

When necessary, this manual will specify further recommendations for the user about the preventive measures, personal protection devices, information aimed to prevent human errors and prohibitions for wrong behaviours which can be reasonably foreseen.

In any case it is necessary to carefully follow the indications here below:

- It is absolutely forbidden to void the safety devices installed in the machine;
- The operations at a reduced safety rate must be performed by carefully following the instructions provided in the relevant descriptions;
- After an operation at a reduced safety rate the normal status of the welder must be restored at the soonest;
- The cleaning operations must be performed with electrical and pneumatic devices switched off;
- Do not modify parts of the welder for any reason: in case of malfunctioning, due to this reason, the manufacturer is not responsible. It is advisable to ask for any modifications directly to the manufacturer.
- Clean the covers of the welder, the panels and the controls with dry soft clothes or slightly wet with a soft cleaning solution; do not use solvents, like alcohol or gasoline, resulting in a possible damage of the welder;
- Place the welder as established upon order; if not, the manufacturer is not responsible for any inconvenience.

1.5 GLOSSARY AND SYMBOLS ON THE WELDER AND IN THE MANUAL

This paragraph lists the words which are not commonly used or which are used with a meaning different from the common one.

This paragraph also explains the short forms used in the manual and the meaning of the symbols used to show the operator skill degree and the status of the welder: their use enables to quickly and easily provide the information necessary to the proper use of the welder under safe conditions.

GLOSSARY:

DANGEROUS AREA: An area inside and/or close to the welder in which the presence of an exposed person is risky for the safety and the health of the same person (Enclosure I, 1.1.1 Directive 98/37/CE);

EXPOSED PERSON: Any person who is fully or partially in a dangerous area (Enclosure I, 1.1.1 Directive 98/37/CE);

OPERATOR: The person in charge for installing, working, adjusting, maintaining, cleaning, repairing and transporting the welder (Enclosure I, 1.1.1 Directive 98/37/CE);

INTERACTION MAN-MACHINE: Any situation in which an operator acts with the welder in any of the operation phases and in any period of the life of the welder;

OPERATOR QUALIFICATION: Minimum skills level an operator must have to carry the described operation out;

OPERATORS NUMBERS: Suitable number of operators for carrying the described operation out in good conditions. This is the outcome of a careful analysis of the manufacturer's: should the operation be carried out by a different number of operators, this could either prevent from obtaining the expected result or endanger the involved personnel's safety;

RESIDUAL DANGER: Danger which was not possible to remove or sufficiently reduce by means of the engineering. The protections are not (or are not totally) effective against this danger. The instruction manual informs about its existence and provides the instructions and the advice for overcoming the same (see, respectively, 5.5 and 5.5.1 of the European Regulations EN 292/1 e EN 292/2);

SAFETY COMPONENT: We mean a component used for ensuring a safety function. Should it be either damaged or work improperly, it would compromise either the safety and/or the health of the exposed people (for instance: lifting tool, fixed, mobile, adjustable protector, etc., electric, electronic, optical pneumatic, hydraulic device interlocking a protector, etc.);

ATTENTION SYMBOLS
(black on yellow background)



ATTENTION! The information enclosed in this paragraph has the utmost importance.



Danger of squashing of upper limbs



Danger of squashing of lower limbs



Emission of magnetic fields.



Inflammable material.



Danger of explosions.



Danger of electric shock.

PROHIBITION SYMBOLS
(black on white background and prohibition in red)



Disconnect voltage.



The use is forbidden to wearers of pace-makers. This is valid both for the operator and for the people around the working area and the cables.



Do not bring near any kind of documents with magnetic strips.



Do not wear watches.

OBLIGATION SYMBOLS
(white on light blue background)



Wear approved goggles.



Protections against noise.



Wear approved gloves.



Wear approved safety shoes.



Specialized personnel only.

2 INFORMATION ABOUT THE WELDER

OPTIONS UPON DEMAND:

2.1 DESCRIPTION OF THE WELDER MAIN FEATURES

- Double handle.
- Flow switch.

AIR OPERATED PRODUCTION SPOT WELDING GUNS WITH BUILT-IN ELECTRONIC TIMER

The following drawings enable to identify the welders' main parts and to learn the terms used in this manual.

- High productivity achieved with rational design, reduced overall dimensions, high welding capacity.
- Reduced installation costs.
- Gyro suspension on balls, together with a spring balancer guarantees accurate manoeuvrability at any degree.
- Rotation locking device.
- Fully water-cooled: electrodes, electrode-holders, arms, and transformer.
- Taps for the water-cooling system make changes easy to be performed.
- Adjustable electrode distance (working stroke).
- Adjustable short working stroke for heavy duty.
- Temporary extra stroke to reach the areas to be welded.
- Long working stroke to weld reinforcement ribs, jobs in areas difficult to be reached, etc...
- Supplied complete with a 30 mA earth leakage switch (different sizes upon request).
- Oil less chromium plated cylinder and shaft for heavy duty operation and long life. Lubrication is not necessary.
- The selectors on the handle enable to choose two welding programs, "pressure only" function.
- Safety device placed on the handle preventing any accidental start.
- Emergency push button, in the welders with built-in control unit.
- Filter-regulator pneumatic group with cutting device.

2.2 IDENTIFICATION OF THE WELDER MAIN PARTS

WELDERS "L" TYPE ITEM 3321 - 3322 - 3324 - 3327 - 3328

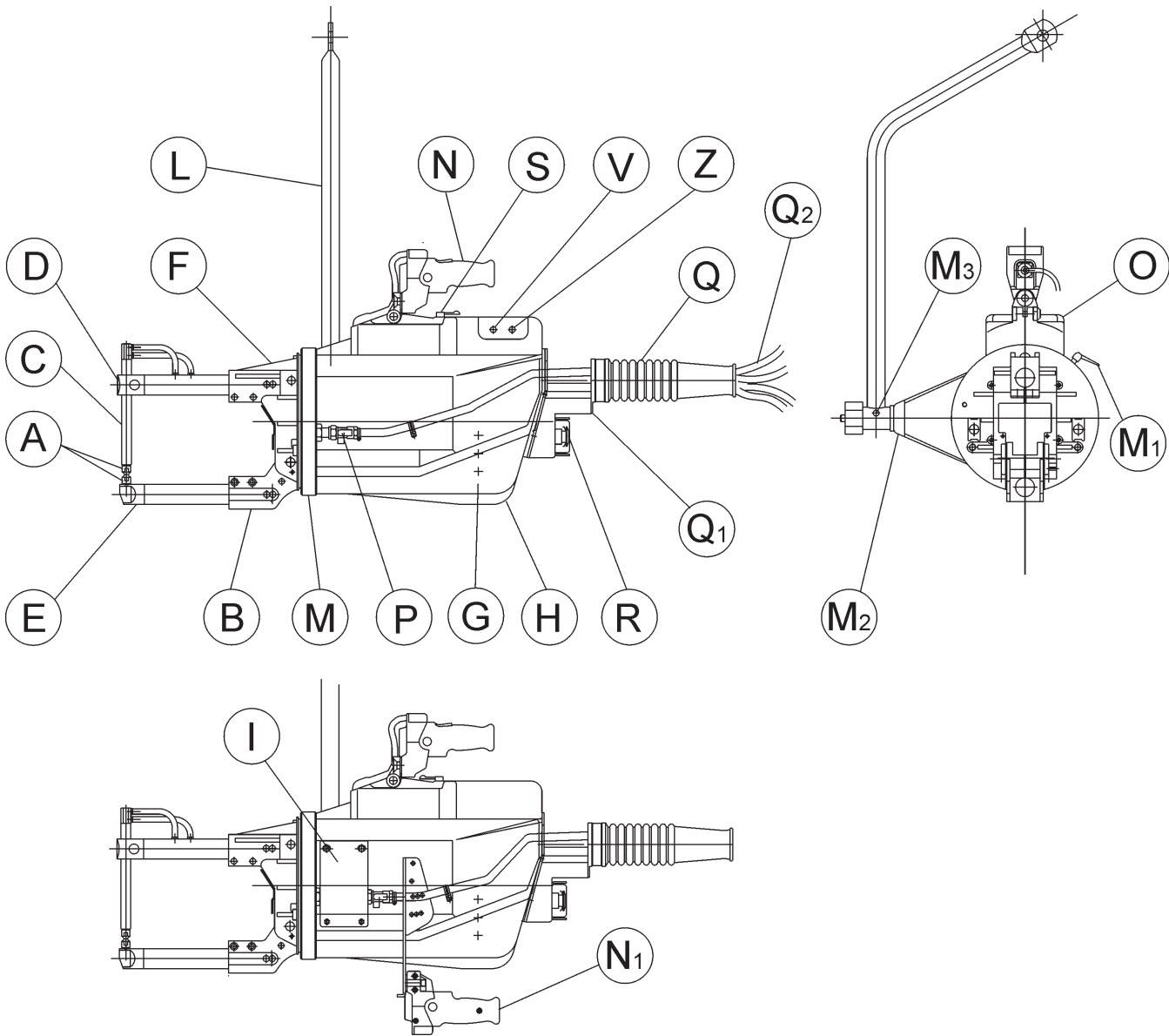

- | | |
|--|---|
| A Electrodes; | M ₃ Horizontal balancing stop; |
| B Lever (movable); | N Handle; |
| C Electrode-holder; | N ₁ Additional handle (option); |
| D Upper arm (fixed); | O Control unit; |
| E Lower arm (movable); | P Valves for stopping the water cooling system; |
| F Front cover; | Q Flexible cable guide; |
| G Stroke adjustment system; | Q ₁ Cable connection box; |
| H Protection for the stroke adjustment system; | Q ₂ Supply cables and hoses; |
| I Flow switch (option); | R Emergency stop button; |
| L Suspension arm; | S Double stroke selector; |
| M Gyro ring; | V Adjustment of electrodes opening speed; |
| M ₁ Gyro ring lock; | Z Adjustment of electrodes closing speed. |
| M ₂ Balancing adjustment guide; | |

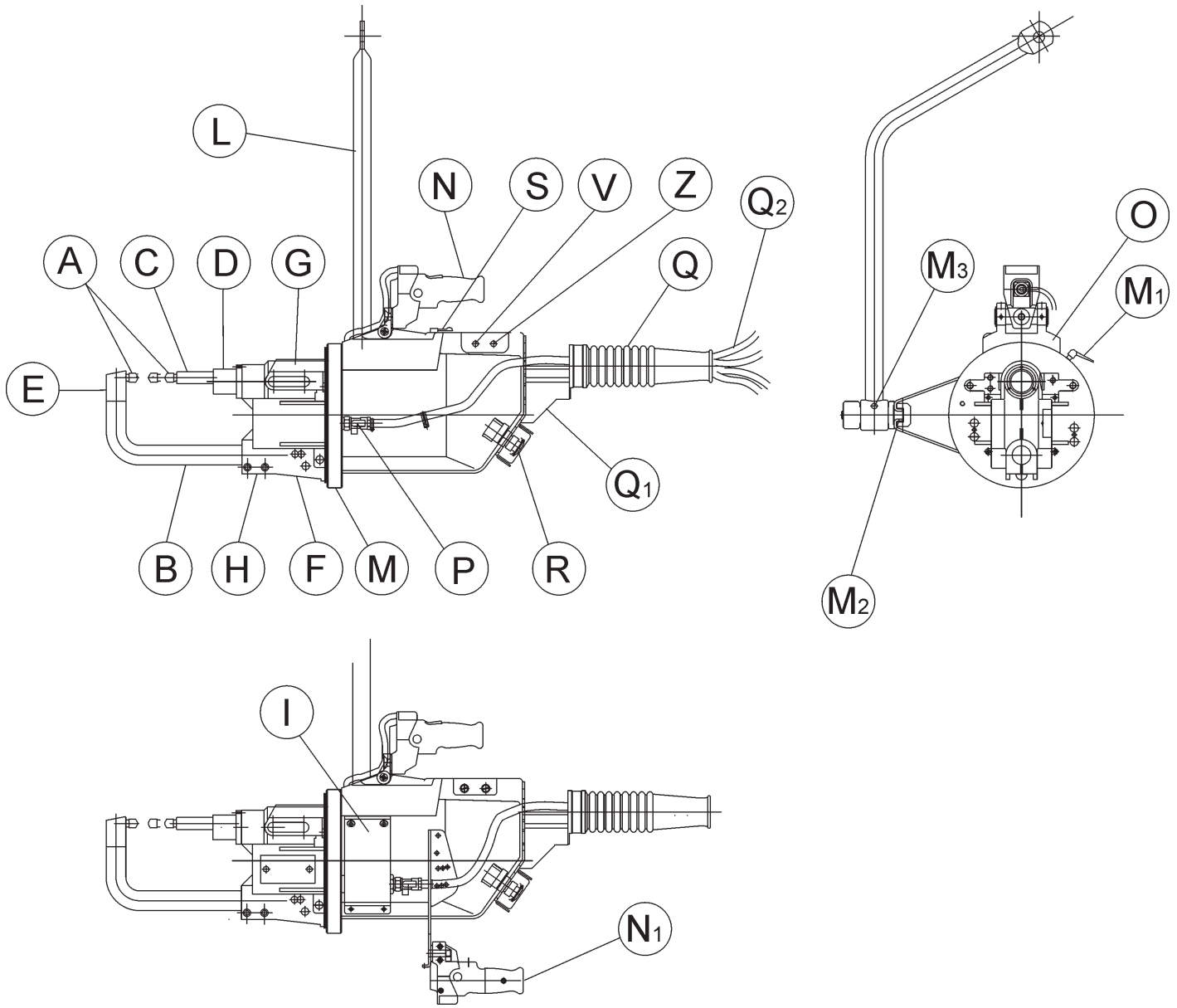

- | | |
|---|--|
| <p>A Electrodes
 B Adjustable fixed arm
 C Movable electrode holder
 D Movable electrode holder protection
 E Electrode holder connection head
 F Front cover
 G Front hoses protection
 H Stroke adjustment
 I Flow switch (option)
 L Suspension arm
 M Gyro ring
 M₁ Gyro ring lock;
 M₂ Balancing adjustment guide;</p> | <p>M₃ Horizontal balancing stop;
 N Handle
 N₁ Additional handle (option);
 O Control unit
 P Valves for stopping the water cooling system;
 Q Flexible cable guide;
 Q₁ Cable connection box;
 Q₂ Supply cables and hoses;
 R Emergency stop button;
 S Double stroke selector;
 V Adjustment of electrodes opening speed;
 Z Adjustment of electrodes closing speed.</p> |
|---|--|

2.3 TECHNICAL DATA

ITEM: _____ FREQUENCY: _____

SUPPLY VOLTAGE: _____

	Art.	3321	3322	3323	3324	3327	3328
Power at 50% rating	kVA	16	23	23	23	38	38
Maximum welding power	kVA	37	65	63	52	110	92
Short circuit current	kA	16	21	21	16,5	27	22,5
Thermal current at 100%	kA	4	4,25	4,25	4,25	5,4	5,4
Secondary voltage	V	2,8	3,8	3,8	3,8	5	5
Cable section L=30m 380/400/415V	mm ²	10	16	16	16	25	25
Delayed fuses380/400/415V	A	32	40	40	40	80	80
Arms centerline	mm	197	197	141	261	204	329
Arms fitting Ø	mm	36	36	36	36	44	44
Electrodes taper	mm	12,7	12,7	12,7	12,7	18	18
Gyro suspension Ø	mm	265	265	265	265	294	294
Minimum arms length	mm	190	190	/	250	250	250
Maximum electrodes force (6 bar)	daN	286	338	300	268	695	695
Working stroke	mm	6÷25	5÷20	5÷20	6÷25	10÷26	10÷26
Maximum stroke	mm	30÷48	28÷40	35÷50	35÷50	45÷60	45÷60
Maximum arms length	mm	650	800	/	650	1030	820
Maximum electrodes force (6 bar)	daN	95	93	/	113	156	196
Working stroke	mm	18÷72	18÷73	/	15÷60	40÷100	30÷75
Maximum stroke	mm	90÷140	102÷146	/	84÷120	165÷225	130÷175
Compressed air supply	bar	6,5	6,5	6,5	6,5	6,5	6,5
Air consumption for 1000 spots (5 bar)	Nm ³	4	4	4	4	7,5	7,5
Supply hose Ø	mm	10	10	10	10	10	10
Cooling water consumption at (2,5 bar)	l/min	7	7	8	7	8	8
Net weight including cables, hoses, gyro suspension and shortest arms	kg	46	52	53	55	76	78
Balancer capacity: with short arms	kg	50÷55	55÷60	55÷60	60÷65	80÷90	80÷90
with long arms	kg	55÷60	65÷70	/	65÷70	95÷105	95÷105
Packing dimensions	mm	300x850x550		330x1120x630		760x1050x500	

OPZIONI

<input type="checkbox"/>	3316	TE450 Welding control unit.
<input type="checkbox"/>	3318	Flow-switch which makes the welder stop if the cooling water does not circulate.

ACCESSORI

<input type="checkbox"/>	3311	Removable key selector for programming lock for TE300 welding control unit.
<input type="checkbox"/>	3312	Removable key selector for programming lock for TE450 welding control unit.
<input type="checkbox"/>	3313	Holder to mount the control handle on the lower side of the spot gun for items 3321-3322-3323-3324.
<input type="checkbox"/>	3314	Holder to mount the control handle on the lower side of the spot gun for items 3327-3328.
<input type="checkbox"/>	3315	Holder to mount the control handle on a spot gun side, complete with another handle without control.

2.4 FORESEEN USE

AIR OPERATED PRODUCTION SPOT GUNS WITH BUILT-IN ELECTRONIC TIMER

ANY USE DIFFERENT FROM AND NOT FORESEEN IN THIS MANUAL MAKES TECNA S.p.A. NOT RESPONSIBLE FOR ANY RISKS SHOULD TAKE PLACE.

In any case, the use of materials different from the ones agreed upon the purchase **EXCLUDES TECNA S.p.A. FROM ANY RESPONSIBILITY FOR DAMAGES TO THE WELDER, THINGS OR PEOPLE.**

The electrical system is not foreseen to be used in anti explosion environments and for flammable products.

3 TRANSPORT AND HANDLING

3.0 GENERAL INFORMATION

The reading of this chapter assumes, in order to safely use the welder, the knowledge of what stated in Chapter 1 Paragraph 4 "General Safety Warnings".

In addition, the specific prescriptions to safely interact with the welder, relevant to this chapter, are detailed in the following paragraphs.

3.1 PACKING

THE WELDER CAN BE PACKED ON PALLET

Then it is covered by a poly-ethylene film to get a higher protection.

Protruding parts are usually disassembled and packed separately.

Upon receipt of the welder, it is necessary to check (visually, with the lorry driver) the complete integrity of the packing and inform any damage to a responsible.



Any damage on the packing should raise doubts about the integrity of the welder.

PACKING FEATURES

PACKING DIMENSIONS: See technical data table

Values subject to change according to the configuration of the welder.

3.2 TRASPORT AND HANDLING OF THE PACKED WELDER

OPERATOR QUALIFICATION	NUMBER OF OPERATORS
	2
SAFETY MEASURES	WELDER STATUS
 	--

NOTICE: The transport of the packed welder must be carried out by qualified personnel by means of an elevator or suitable lifting devices.

DESCRIPTION CONCERNING THE LIFTING BY ELEVATOR



Before starting any transport operation, pay attention that the capacity of the elevator is suitable to the load to be lifted.

Position the forks in the correct position only. Once the forks are positioned, lift them slowly avoiding sharp movements.

Do not stop for any reason in the operation area and do not climb on the pallet while in movement.

3.3 STORAGE OF THE WELDER BOTH PACKED AND UNPACKED

For all the time the welder is not used before unpacking, store it in a dry place with an environment temperature included between + 0°C and + 40°C and in such a position so that it is not in contact with the rain. (FOR STOCKAGE ONLY, if water cooling system is emptied, the welder can be kept up to -20 °C)

Protect the welder during the whole period of inactivity (for example before being installed or in case of production stop) after its unpacking.



3.4 UNPACKING

UNPACKING OF PALLET WITH PROTECTIVE FILM

Transport the welder close to the place of installation, then:

- Take off the plastic protection which covers the welder paying attention not to damage it.
- (Visually) check the external integrity of the welder.
- Check that the welder is complete with all the standard accessories; should some parts be missing, immediately inform the manufacturer.
- All the material forming the package must be scrapped according to the present environmental safety regulations.

3.5 HANDLING OF THE UNPACKED WELDER

OPERATOR QUALIFICATION	NUMBER OF OPERATORS
	2
SAFETY MEASURES	WELDER STATUS
 	--

NOTICE: The transport of the unpacked welder should be performed by skilled personnel by means of either a fork elevator or strip /chain lifting conveyors.



Pay attention, before transporting the welder, that the capacity of the elevator is suitable with the load to be lifted.

The welder must be handled only by means of its own suspension system.

Handling of the welder without suspension arm

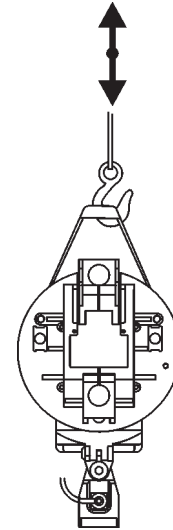

Handling of welder with suspension arm

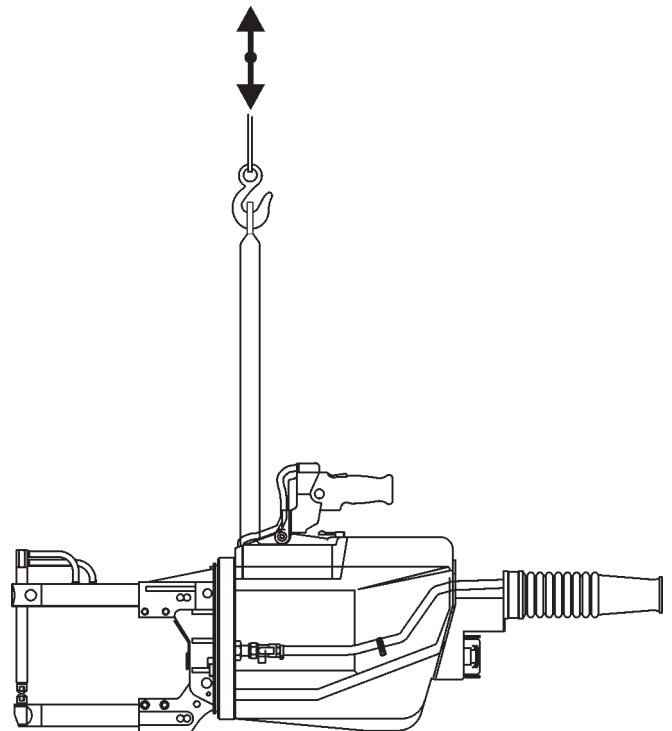

Until the suspension arm is not mounted in the welder, use the proper hole located on the suspension fixing plate. Once the suspension arm has been installed, use the same for handling the welder. Take into consideration the welder weight as shown in the paragraph "TECHNICAL FEATURES".

4 INSTALLATION

4.0 GENERAL WARNINGS

The reading of this chapter, to the purpose of the safe use of the welder, assumes the acknowledgement of the Chapter 1, Paragraph 2 "General Safety Warnings".

These paragraphs are intended for specialized personnel responsible for the handling and installation of the welders.

Moreover, the specific prescriptions for safely interact with the welder, relating to this chapter, are detailed in the following paragraphs.

4.1 REQUIRED ENVIRONMENT CONDITIONS

The machine is intended to work under the environmental conditions specified in the following points, if not otherwise state in the order form:

TEMPERATURE

The welder can work at a room temperature included between 0°C and + 40°C. (FOR STOCKAGE ONLY, if the water is removed from the water cooling circuit, the welder can be stored up to -20 °C)

HUMIDITY

The welder can work at a humidity varying from 15% to 95%.

ALTITUDE

The welder can work at a max. 1000 m altitude without a lowering of performance.

ILLUMINATION

The welder has been designed taking into account the prescriptions to make the operator work easily. The lighting system of the plant is also important for the people safety.

EXPLOSIVE AND/OR FLAMMABLE ATMOSPHERE

The standard version of the welder is not designed to work in either explosive atmosphere or flammable ones.

4.2 LOCATION OF THE WELDER

The welder should be installed in a position having the following features:

- Indoors, the welder is not designed for working outdoors.
- In a well ventilated area, free from dust, steam and acid exhalations.
- The working place must be free from inflammable materials because the working process can produce spatters of melted metal.
- Around the welder there must be enough room to carry out both working and maintenance in a comfortable manner and without any risk.
- In a place with a suitable lighting system in comparison with the work to be carried out.
- The place of installation must be necessarily flat and the ground must be without unevenness which can be dangerous when working.

If the welder is used to carry out welding processes which can cause smoke exhalations, a proper aspirator must be installed.

4.3 ACCOMPLISHMENT OF THE ASSEMBLY

SUSPENSION SYSTEM

OPERATOR QUALIFICATION NUMBER OF OPERATORS



2

SAFETY MEASURES MACHINE STATUS



--

The suspension arm is supplied disassembled from the welder; therefore it is necessary to assemble it as per the following drawing. It is important to mount and well tighten the safety nut (a) so that the fall of the welder is avoided in case Y1 nut is accidentally unscrewed.

Prepare a suspension suitable to the work to be made. It is advisable to suspend the welder to a balancer which enables the operator to use the welder with the minimum effort.



The installation of the balancer is a seriously risky operation. Carefully read the balancer instruction manual and follow its prescriptions.

The balancer should be equipped with a device which electrically insulates the welder from the structure to which it is suspended; this avoids an eventual current flow of the welding current to the suspension system. Rotary insulated hooks can be used for this purpose: they also avoid having twists on the balancer rope.

When the balancer (and the safety rope) has been hooked to the support, it is necessary to adjust its capacity.

It is recommended to leave a slight tendency to slope up in order to get better results. Once the balancing has been accomplished, check that all the rope of the balancer can fully exit so that the spring is not too much pre-loaded to limit the stroke.

Once the assembly of the suspension system has been accomplished it is necessary to carry out the balancing adjustments, see "SUSPENSION ADJUSTMENT" paragraph.

Art. Item 3321 - 3322 - 3323 - 3324

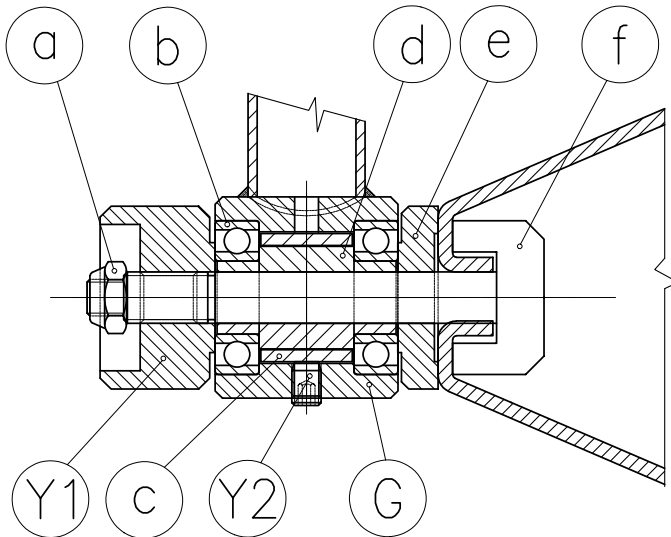

- a Safety nut
- b Bearing
- c Bushing
- d Bushing
- e Suspension washer
- f Suspension screw
- G Suspension arm
- Y1 Suspension locking nut
- Y2 Headless screw

Art. Item 3327 - 3328

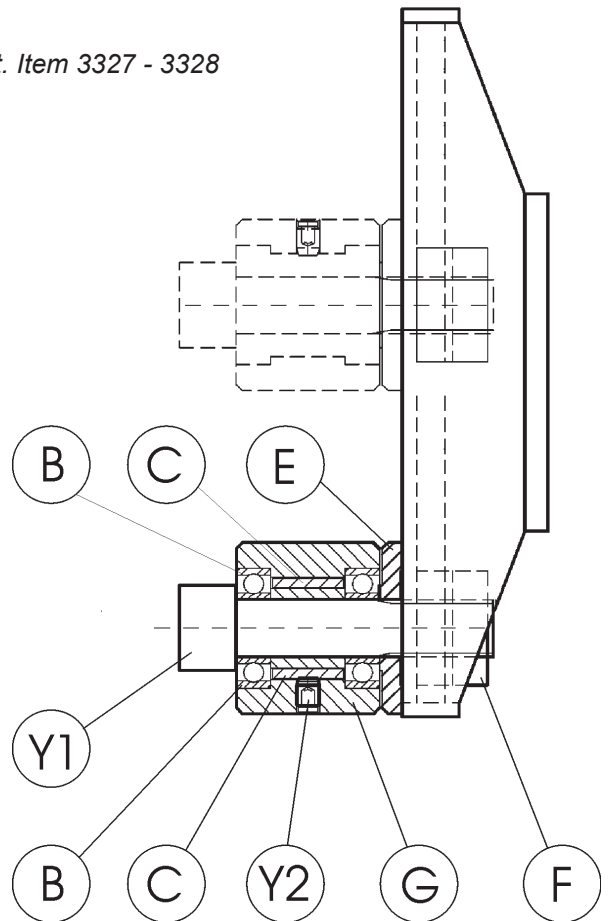

- B Bearing
- C Bushing
- C Bushing
- E Suspension washer
- F Suspension screw
- G Suspension arm
- Y1 Pin
- Y2 Headless screw

4.4 CONNECTION TO THE ELECTRIC SUPPLY

PNEUMATIC CONNECTION

OPERATOR QUALIFICATION	NUMBER OF OPERATORS	SAFETY MEASURES	MACHINE STATUS
	1		--



Before performing any connection to the system of the plant check the perfect cleaning of the hoses: they should be free from any external dust, remaining from the unpacking or from storage in an inconvenient place.

For a proper connection of the welder to the compressed air supply it is necessary to have a centralized plant or a compressor able to produce dry and cool air within the maximum pressure limit and in the quantities shown in the "Technical Features" paragraph. The minimum diameter of the hoses mentioned in the same paragraph (example A) should be taken into consideration.

In case the line is subject to high pressure changes it is advisable to supply the welder with a tank sized at least 25÷50 litres which is supplied by means of a one-way-directional valve (example B).

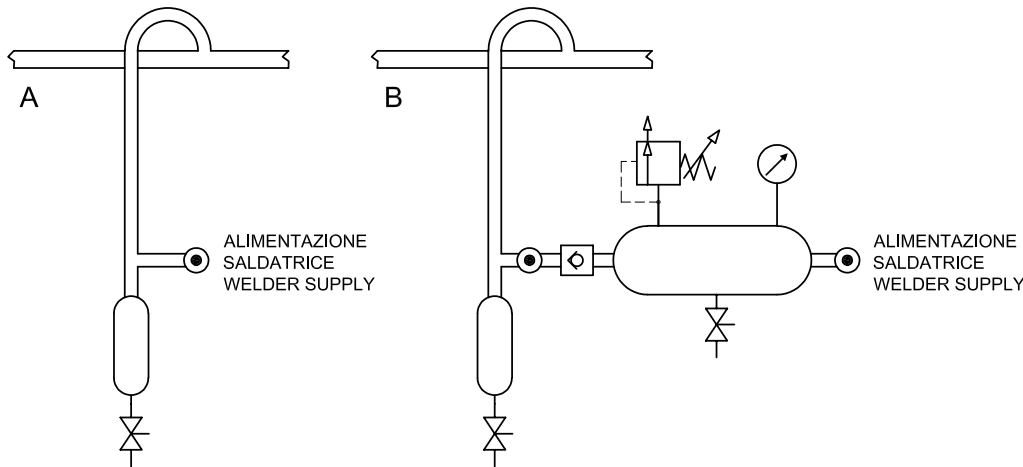

Pneumatic installation examples

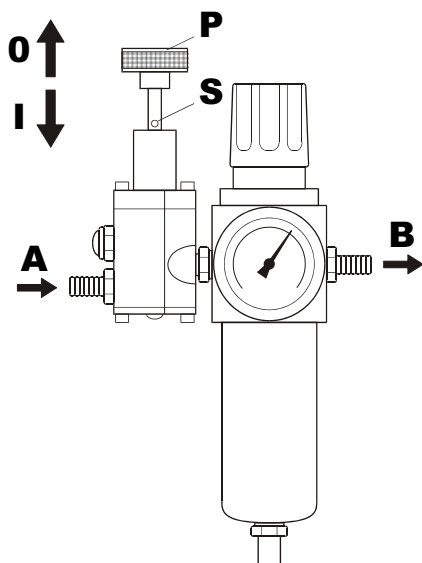

- P** Control knob
- S** Blocking hole with lock
- A** Compressed air supply
- B** Compressed air outlet for welder
- O** Cutting device opening: extract the knob P
- I** Cutting device closing: press the knob P

The welder is equipped with a filter which automatically discharges the mist and it must absolutely be installed in a vertical position. The welder is manufactured with components which do not require lubrication. If a component which requires lubrication is installed in the welder; attention has to be paid to the fact that this implies emission of oil mist in the environment.

A device to cut the pneumatic supply is installed in the filter group. Besides being hand-operated, this device automatically disconnects the supply when the pressure goes beyond 3÷4 bar. This enables to avoid sudden movements in case of a temporary absence of the pneumatic supply.

To cut the supply of the compressed air (for example when you need to perform maintenance operations), take out the knob P. If it is necessary to grant the safety of the cutting device it is possible to add a lock in the hole of stem S. To supply the welder press knob P.

CONNECTION TO THE COOLING SYSTEM

OPERATOR QUALIFICATION NUMBER OF OPERATORS



1

SAFETY MEASUREMENTS WELDER STATUS



--



Before performing the connection to the plant system, check the perfect cleaning of the welder hoses: they should be free from any external accidental remain of the unpacking, or from storage in an inconvenient place.

For a proper cooling of the welder it is necessary to use clean water at a maximum temperature of 30 °C in the quantity shown in the paragraph “Technical Features”.

When performing the connection, pay attention that the hoses are free from dirt or from remains of package. Then connect the supply to the inlet and the discharge to the outlet; this is to allow the water which is still cold to reach the parts of the welder that are most subject to heating.

It is possible to have different water cooling systems: by means of a closed circuit, of a water-air heat exchanger and by a water cooler. If the circuit is closed or with a water cooler and the air in the working environment has a high percentage of humidity, it is advisable to avoid water at a low temperature – lower than 20° C as this could cause moist inside the welder.

If water is hard or calcareous it is necessary to install a water softener at the inlet hose of the water-cooling circuit of the welder; this is to avoid that deposits obstruct or reduce the water cooling hoses causing damages to the welder. In case of water cooling by closed circuit, this softener should be positioned before the supply of the bath which contains the water used for cooling.

We recommend using water with a maximum hard water of 10 °fH (French degrees). 1 °fH (French degree) corresponds to 0.56 °dH (German degree), and to 0.7 °eH (English degree).

Check that the water being used is clean. Suspended particles in the cooling liquid might sediment in the machine reducing or cancelling the cooling capability and causing serious damages. For this reason it is always advisable to assemble a proper filter on the machine supply.

Once the installation has been accomplished, it is necessary to check that the water flow in the welder corresponds to the quantity shown in “Technical Features” paragraph.

ELECTRICAL INSTALLATION

OPERATOR QUALIFICATION NUMBER OF OPERATORS



1

SAFETY MEASURES WELDER STATUS



--



The welders in this manual have been designed exclusively for professional use in an industrial environment. They must not be installed in low voltage public lines which supply domestic premises. This can cause electromagnetic interferences.

The electrical installation of the welder to the mains supply is carried out by the customer at his own exclusive risk and responsibility, by using specialized personnel who should carefully follow the indications of this instruction manual.

Before connecting the welder to the mains supply check if the voltage shown on the features plate corresponds to the one of your mains supply.

When realising the supply line of the welder consult the “Technical features” table to determine the cables section to be used. These values are the minimum advised. However, they must be checked taking into consideration the installation conditions, the typology of the materials being used, and the laws in force in the installation place.

The welder is equipped with an earth leakage circuit breaker located at the end of the supply cable. Besides breaking the electric supply, this device has safety functions therefore it must not be absolutely taken off. **The switch must be installed close to the working place so that the operator can easily reach it.** If the breaking capacity offered by the earth leakage circuit breaker is not adequate to the mains system, or if it is required by the laws in force, install delayed fuses in the size shown in the “Technical Features” paragraph granting an adequate breaking capacity.

The paragraph TECHNICAL DATA 2.3 reports the features of the supplied switch.

The connection of the welder to the protection conductor (earth conductor) is compulsory. Check that the conductor of the protection system is efficient and complies with the laws in force.

5 WELDER SET UP

5.0 GENERAL NOTICE

The reading of this chapter assumes, to the purpose of a safe use of the welder, the acknowledgement of what is stated in Chapter 1 Paragraph 4 "General safety warnings".

Besides, the specific prescriptions to safely operate the welder, relating to this chapter, are detailed in the following paragraphs.

5.1 DESCRIPTION OF THE WELDING CONTROL UNIT

The welder can be equipped with different types of control units, either external to or built-in the welder. The following paragraphs describe the features of the different available types.

5.1.1 BUILT-IN CONTROL UNIT TE300

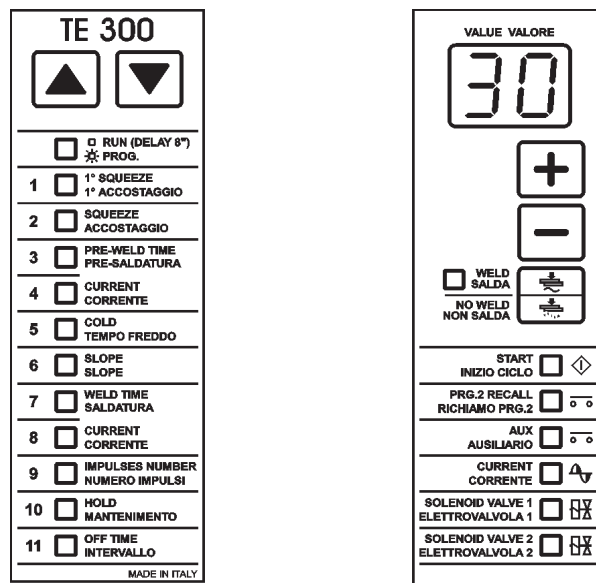

The function of the control unit is to manage the parts of the welders, in particular the thyristor adjusting the welding current. TE300 is a microprocessor welding control unit for resistance welding suspended spot guns. This control unit includes specific functions to be used when working with suspended spot guns.

It is possible to set 2 different welding programs which can be recalled by an external device. Each program is formed by 10 programmable parameters which describe the working cycle. Besides the simple 4 times cycle, the control unit enables to carry out welding processes with pre-weld current and pulses. Another available function of this control unit is the compensation of the minimum current.

MAIN TECHNICAL DATA

- Easy programming by 5 push-buttons
- Synchronous thyristors drive device with phase shift control for welding current adjustment.
- 2 welding programs to be stored up and selectable by an external device.
- 10 programmable parameters for each program.
- Slope, pulses and pre-weld functions.
- Single and automatic cycle.
- Compensation of the secondary current to weld oxidised sheets and rods.
- WELD / NO WELD function.
- Delay of first phase shift adjustment, to get the best balance of the welder absorption from the mains.
- Control of 2 solenoid valves 24 Vdc 7,2 W Max with protected output against short circuit: electrode closing valve and double stroke valve.

For further information concerning TE300 see relevant instruction manual.

5.1.2 BUILT-IN CONTROL UNIT TE450

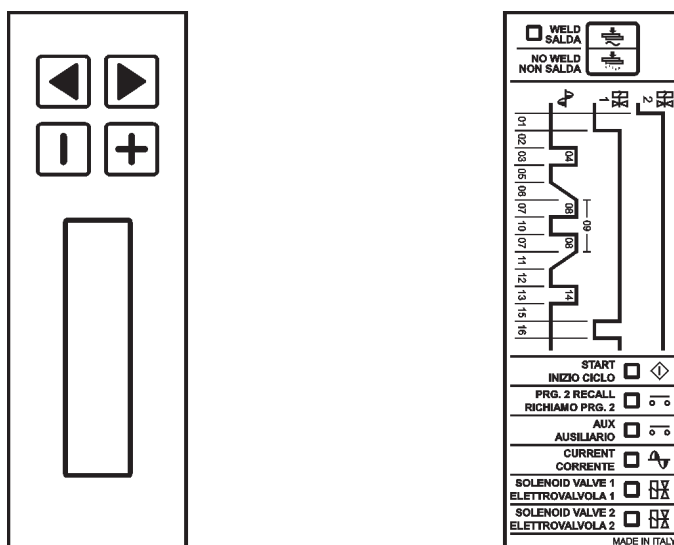

The welding control unit is used to control the welder parts and, in particular, the thyristor adjusting the welding current. TE450 is a microprocessor welding control unit for resistance welding suspended spot guns. This control unit includes specific functions to be used when working with suspended spot guns. The handle is not a standard component of the welding control unit; it is possible to install different handles so to set the machine according to different working needs. It is possible to store up to 63 different welding programs; it is possible to directly recall 2 programs by means of an external selector usually installed on the handle. Each program is formed by 18 adjustable parameters describing the working cycle. Besides the simple 4 times cycle, the control unit enables to carry out welding processes with pre-weld, post-weld current, slope and pulses. TE450 can work in constant current mode; it displays the welding current and check the current according to set limits.

MAIN TECHNICAL DATA

- Easy programming by means of 5 push-buttons and LCD alphanumeric display.
- Synchronous thyristors drive with phase shift control for welding current adjustment.
- 63 welding programs to be stored up, 2 of them can be recalled from an external device.
- 18 programmable parameters for each program.
- Slope, pulses, pre-weld and post-weld functions.
- Welding times adjustment in half-periods.
- Display of both welding current in kA and relevant conduction angle.
- Double working mode: standard and constant current.
- Either welding current or conduction angle limits.
- Stepper function to balance the electrodes wear with adjustable curve.
- Welds counter.
- Compensation of secondary current to weld oxidised sheets and rods.
- Single and automatic cycle. WELD / NO WELD function.
- Delay of first phase shift adjustment to get the best balance of the machine absorption from the mains.
- Control of 2 solenoid valves 24 Vdc 7,2 W Max with protected output against short circuit: electrode closing valve and double stroke valve.

For further information concerning TE450 see the relevant instruction manual.

5.2 ELECTRIC GENERAL SWITCH (Emergency Interruption)



Following to a dynamic-type action and while being supplied, the machine is designed for being stopped in **EMERGENCY INTERRUPTION** conditions by the operator by acting on the machine's general switch so to remove an electric danger.



The placing in service of the welder after an emergency condition must be carried out only by qualified personnel trained to accomplish all the machine necessary tests. If the machine was stopped during the welding process, it is necessary to execute the following procedure before restart the production in order to restore the normal transformer magnetisation condition: carry out some welds with an insulator placed between the electrodes with different current adjustments, first low ones, then progressively higher; remove the insulator between electrodes and execute some welds with a low current adjustment; at this point the procedure ends and the normal functioning conditions are restored.

In case of any water leakage which could enter the welder, immediately disconnect the electric supply.

In case of fire do not use water but proper fire extinguishers.

5.3 SAFETY RULES

OPERATOR QUALIFICATION NUMBER OF OPERATORS



1

SAFETY MEASURES WELDER STATUS



For a safe welder employ, the installation must be carried out by specialised personnel following all the instructions stated on the "INSTALLATION" chapter.

The welder maintenance must be carefully carried out by following all the safety instructions stated on the "MAINTENANCE" chapter. In particular, notice that the electrodes maintenance must be carried out according to either one of the following conditions:

- with the welder switched off.
- with the emergency button pressed down.



The welder should be operated by trained personnel only; in any case, users operating the welder must be aware of the possible risks and must have both read and understood this manual.



Only authorised personnel can carry out the welder adjustment. The welder adjustments affect the operative safety so much so that they must be carried out by qualified personnel only.

Carefully follow the instructions stated on the "WORKING PROCESS" chapter.



It is forbidden to have more people working on the welder at the same time. No admittance allowed to the working area to people other than the operator.



In case of water entering the welder, immediately stop the electrical supply.

When operating heavy working, high thickness and pieces with a difficult coupling, wear safety shoes and aprons, and use protection screens to protect the operator from possible spatters of melted materials.

The safety shoes must be worn each time the pieces to be welded, because of their shape or weight, bear risks requiring them.



Keep the welder's nearby working area free from flammable materials. In case the material to be welded produces either smokes or exhalations, install a proper aspirator.



The noise produced by the welder depends mainly on the adjustments. To reduce the noise:

Adjust the working stroke to the minimum value allowing carrying out the operation.

- Adjust the working stroke to the minimum value allowing carrying the operation out.
- Work having the double stroke activated.
- Adjust both the electrodes opening and closing speeds to low values.
- Periodically check the silencers.

Should the noise produced by the welder during the working phases exceed the safety threshold, wear the proper protection headphones.

In addition to the information stated on this chapter, always operate in accordance with all the relevant laws in force.

5.4 MACHINE FUNCTIONING

OPERATOR QUALIFICATION		NUMBER OF OPERATORS
OPERATOR		1
SAFETY MEASURES		WELDER STATUS
		ON

The welder was designed for being used by an operator placed as represented in the pictured examples:

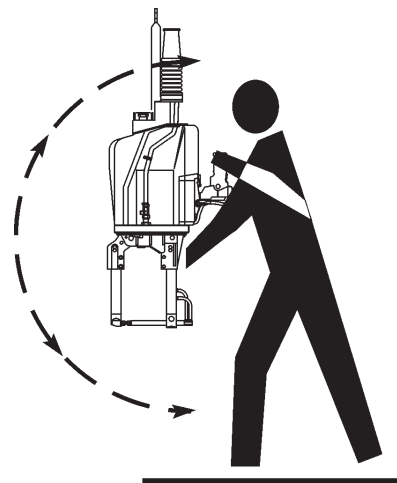
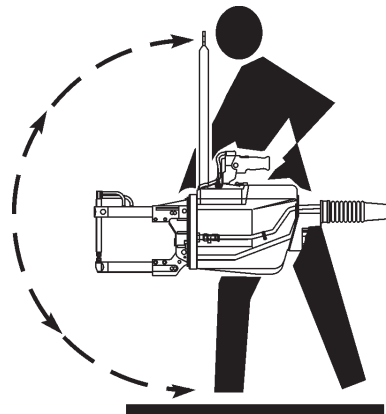
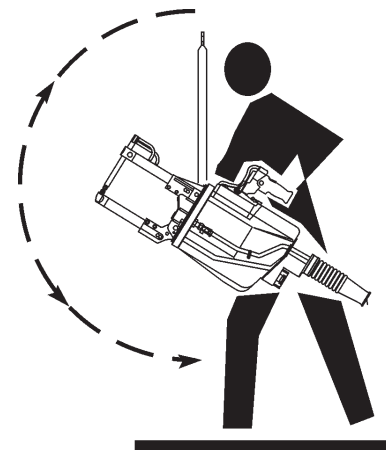

When arranging the working place, always follow the instructions mentioned below:

- Use a well ventilated area, free from dust, steam, and acid exhalations.
- The working place must be free from inflammable materials because the working can produce sparks and projections of melted metal.
- Around the welder there must be enough room to carry out both working and maintenance in a comfortable manner and without any risk.
- If the welder is used to carry out welding processes which can cause smoke exhalations, there must be installed a proper aspirator.

Before starting the working process, carry out the following adjustments:

- 1) Mechanical set up
- 2) Electrode force adjustment
- 3) Welding parameters adjustment
- 4) Calculation of the maximum welding rating

The following paragraphs carefully explain these different phases.

Before starting the working process:

- Check that all the safety instructions have been operated.
- Check that the automatic cycle is inserted only when it is really used.
- Check that the pneumatic circuit is supplied.
- Check the correct functioning of the control devices.
- Carry out some test cycles in order to verify both the cycle correctness and the operating speeds. These tests should be carried out without current circulation by means of the WELD/NO WELD selector placed on the control unit.

Before starting the welding process, check the welding conditions (time, pressure, etc.). Use two off-cuts of the sheet to weld, carry out two spots at the same distance used during the production, then remove the first and check the second: the spot is correct when the pulling test causes the coming out of the weld nugget with the hole of a sheet, and the twist test shows a pure area without porosity or causes the coming out of the nugget.

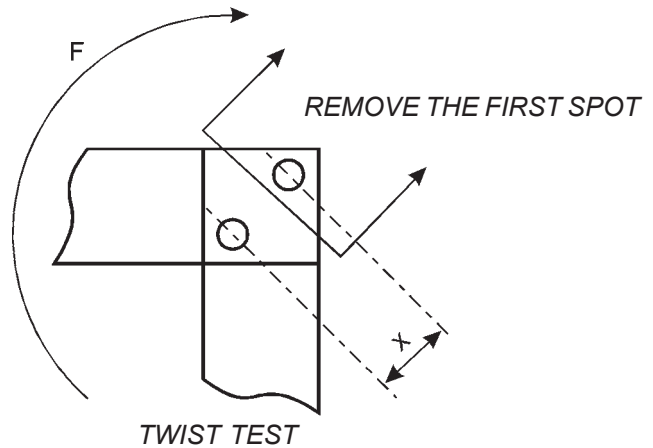

X=SAME DISTANCE OF SPOTS IN PRODUCTION

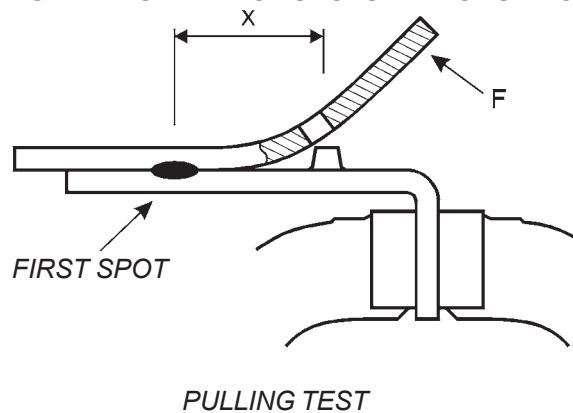

During the production it is advisable to monitor those parameters which can alter the working conditions, and thus the welds quality. Always monitor the electrodes which must always be clean, without any deformation and must have the proper diameter according to the work to be carried out. Check that there is no strong changing in the welder supply pressure as this could modify the force at the electrodes and thus the welding quality.

Do not use sealing products to remove water losses on the electrodes conic connection. To facilitate the electrode removal and to prevent from both cone seizure and water losses, use high conductivity grease like the one delivered in the standard equipment.

The cooling water must circulate inside the welder for a few minutes after having completed the production in order to allow the welder cooling. To prevent from both losses and moisture deposits, do not leave the cooling circuit open when the unit is not used.

Electrodes must not be used to force the clamping of the pieces to weld.

We recommend you to notice the adjustments carried out for each type of piece. In order to make it easier, a specific table has been added at the end of this manual.

DESCRIPTION OF THE CONTROL DEVICES

The welding cycle start is obtained by acting on the cycle start button (1). As long as the welding process has not started, the gun would immediately reopen if the cycle start button is released.

These welding guns are equipped with a safety micro-switch (2) placed on the handle's back. This one enables the cycle start only if the operator grasps the handle.

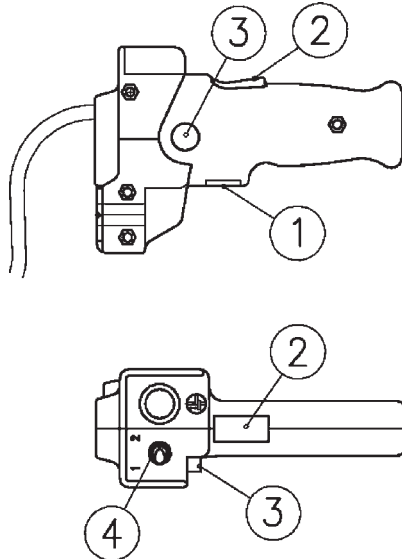

The button (3), placed on the handle's side, allows using the "PRESSURE ONLY" function. Usually, this device is used for checking that the electrodes are correctly placed before carrying the welding process out.

By activating the control "PRESSURE ONLY" (by pushing the button 3) while the electrodes close, the welder clenches the pieces to be welded and wait for the operator to continue the cycle by removing the control "PRESSURE ONLY" (by releasing the button) once he has checked that the electrodes are correctly placed.

If the electrodes are correctly placed then the operator may cancel the operation by releasing the cycle start control.

The selector (4) enables to quickly select two different welding parameters adjustments. The adjustment selection must be carried out before the welding cycle start.

For further information, please refer to the control unit instruction manual.

Upon demand, the welding gun may be equipped with other handles to have it suitable for the different working needs.

KEY SELECTOR FUNCTION (OPTIONAL)

Upon demand, the welding control unit may be equipped with a two-position key selector. This one allows disabling the control unit programming when one wishes that the user cannot modify the welding programs.



- BLACK: DISABLED PROGRAMMING
- RED: ACTIVATED PROGRAMMING

By positioning the key according to the black reference, all programming operations will be inhibited.

EMERGENCY SWITCH

An EMERGENCY button is placed in the machine's rear part. When on NORMAL position it is possible to use the welder. When on PRESSED position, the welder functioning is disabled. The electrodes maintenance must always be carried out when having this button in the PRESSED position.

5.5 RESIDUAL RISKS



The welder main risk is the squashing of the upper limbs caused by the moving of the electrodes. It is, therefore, necessary to pay careful attention and follow all the instructions included in the instruction manual, particularly:

- Adjust the welding stroke to the minimum possible value.
- Avoid working having the hands close to the electrodes.



Notice that these types of machines generate strong magnetic fields attracting metals and damaging watches, magnetic cards and magnetic data storage media. Since these magnetic fields can affect pace-makers, hearing aids and any electric medical device, the wearers must consult their doctor before approaching to the welding area.



The personnel must wear safety glasses, gloves and accident-prevention shoes. Avoid wearing rings, metal watches and clothes with either metal accessories or components.

6 MACHINE USE

6.0 GENERAL INFORMATION

The reading of this chapter assumes, in order to safely use the welder, the knowledge of what stated in Chapter 1 Paragraph 4 "General Safety Warnings".

In addition, the specific prescriptions to safely interact with the welder, relevant to this chapter, are detailed in the following paragraphs.

6.1 CALCULATION OF THE MAXIMUM WELDING RATING

Before starting the production, it is necessary to check that the welding rating does not exceed the maximum welding rating allowed by the welder in comparison with the set welding conditions (time and current), otherwise causing a too high over heating.

To carry out this test, it is necessary to know the used welding current which must be measured with an adequate welding ammeter. The control unit is equipped with an integrated ammeter (TE450-TE510).

The welder maximum welding rating is the function of the thermal load applied to the welder itself, depending on both the used time and welding current and on the numbers of welds for unit of time. With these different parameters it is possible to define the I_{th} value, that is to say the "equivalent thermal current at the duty cycle of 100%". Its value is calculated as follows:

$$I_{th} = \sqrt{\frac{\text{number of welding cycles per minute} \times (\text{welding current in kA})^2}{3000}}$$

The resulting value must be lower than the welder maximum one; this value is stated on the "Technical Features" paragraph. Otherwise, it is necessary to reduce the welding rate.

When different welding programs or when a welding cycle with pre-heating or post-heating are employed, the value of these different currents must be calculated separately, and then added in order to obtain the equivalent total value.

Example 1: Cycle simple

Welding current = 13000 A
Welding time = 18 periods
10 welds per minute

$$I_{th} = \sqrt{\frac{(18 \times 10) \times (13000)^2}{3000}} = 3184 \text{ A}$$

Example 2: Cycle with pre-weld

Welding current = 20000 A
Welding time = 12 periods
Pre-weld current = 9000 A
Pre-weld time = 4 periods
6 welds per minute

$$I_{th1} = \sqrt{\frac{(12 \times 6) \times (20000)^2}{3000}} = 3098 \text{ A}$$

$$I_{th2} = \sqrt{\frac{(4 \times 6) \times (9000)^2}{3000}} = 805 \text{ A}$$

$$I_{th} = \sqrt{I_{th1}^2 + I_{th2}^2} = \sqrt{(3098)^2 + (805)^2} = 3200 \text{ A}$$

Example 3: Cycle with pre-weld and post-weld

2 welds per minute
Welding current = 18000 A
Welding time = 18 periods

$$I_{th1} = \sqrt{\frac{(18 \times 2) \times (18000)^2}{3000}} = 1972 \text{ A}$$

6 welds per minute
Welding current = 9000 A
Welding time = 12 periods

$$I_{th2} = \sqrt{\frac{(12 \times 6) \times (9000)^2}{3000}} = 1394 \text{ A}$$

$$I_{th} = \sqrt{I_{th1}^2 + I_{th2}^2} = \sqrt{(1972)^2 + (1394)^2} = 2415 \text{ A}$$

NOTE: Above formulas are for 50Hz supply lines. For 60Hz supply lines change the "3000" value with "3600".

6.2 TROUBLESHOOTING



Troubleshooting must be carried out by specialised personnel only, equipped with the proper instruments and trained to accomplish it under safety conditions. When possible, disconnect both electric and pneumatic supply.

Shouldn't the welder work properly, use the following table to identify the trouble and find the proper remedy.

FAULT	CAUSE	REMEDY
The control unit does not switch on. Control unit led ON keeps off.	Either connectors or cables disconnected	Check.
	The fuses FU1-FU2 placed inside the control unit intervened.	Identify what caused the fault. Check the wiring. Replace the fuses.
	Cut supply cable.	Check and eventually intervene as described in 8.2.2
	Check fuse on boards for TE450.	Replace the fuses.
The control unit does not switch on. Control unit led ON is on.	Inadequate mains voltage	Check.
	Faulty control unit.	Replace.
The welder carries out the welding cycle without current circulation. Control unit CURRENT led is off during the welding cycle.	WELD/NO WELD function set to NO WELD.	Set to WELD.
	Faulty control unit.	Replace.
The welder unit carries out the welding cycle without current circulation. The control unit CURRENT led lights.	Faulty contact in the secondary circuit.	Check and tighten all the secondary connections. Do not forget the connection between the electrode and the electrode-holder.
No electrode descent. Welding control unit led EV1 lights.	Lack of compressed air.	It is shown by the corresponding manometer. Operate.
	Inadequate welding pressure.	It is shown by the corresponding manometer. Increase it by means of the pressure regulator.
	Broken connection between the control unit and the solenoid valve.	Check.
	Faulty solenoid valve EV1.	Replace it
Too slow or not uniform electrodes descent.	Inadequate welding pressure.	It is shown by the proper pressure gauge. Adjust it correctly by means of the pressure gauge.
	Faulty adjustment of the flow-regulator relevant to the closing speed Z.	Adjust it correctly.

FAULT	CAUSE	REMEDY
Inadequate welding force at the electrodes.	Inadequate welding pressure.	It is shown by the corresponding manometer. Adjust it correctly by means of the pressure gauge.
The electrodes do not rise up after welding.	Inadequate welding pressure.	It is shown by the corresponding manometer. Adjust it correctly by means of the pressure gauge.
	Faulty adjustment of the flow-regulator relevant to the opening speed V.	Adjust it correctly.
By pressing the start, the control unit displays "THERMOSTAT OR FLOW-SWITCH ACTIVATED"	Inadequate or missing water circulation. The flow-switch SF1 or the thermostat protecting the transformer intervened.	Check that the water circulates in the required quantity. Check the thermostat functionality. In case the flow-switch is present, check the water circulation direction.
Spots or electrodes overheating.	Insufficient cooling.	Check that water circulates in the required quantity and at a low temperature.
	Too high welding current or welding time.	Reduce.
	Pre-welding, Post-welding (TE450) or currents with too high time and/or too high current.	Modify.
Electrodes reduced life.	Insufficient cooling.	Check that water circulates in the required quantity and at a low temperature.
	Under-seized electrodes in comparison with the work to carry out.	Check both seize and contact diameter.
Secondary connections reduced life.	Insufficient cooling.	Check that water circulates in the required quantity and at a low temperature.
	Heating caused by an inadequate clamping of the flexible connection.	Carefully tighten the clamping screws.
	Too high heating caused by a too high welding rate.	Reduce it.

6.3 REMEDIES FOR WELDS IMPERFECTIONS

This chapter has been introduced in order to facilitate the troubleshooting of the most common imperfections caused by a wrong adjustment. Notice that each fault can be caused by different causes, as there are many parameters affecting the welding process. The following table specifically refers to low carbon steel spot welding, but, with the due considerations, it can be used for other applications also.

FAULT	POSSIBLE CAUSE	POSSIBLE REMEDY
Weak welding.	Low welding current. Low welding time. Too high electrodes force. Lacking electrodes maintenance or too high electrodes diameter. Faulty pieces contact.	Increase it. Increase it. Reduce pressure. Clean and line up the electrodes, restore their dimensions. Increase the electrodes force.
Spatters of melted material	Paint or dirt among pieces. Inadequate electrodes cooling. Faulty pieces contact or pieces and electrodes faulty contact. Too high welding current. Too high welding time. Too small electrodes diameter. Inadequate welding force. Electrodes faulty clamping of the pieces.	Clean the pieces. Check the cooling circuit. Increase the electrodes force by increasing pressure. Reduce it. Reduce it. Adjust diameter to the suitable value Increase pressure to the suitable value. Check stroke.
Burned welds or welds showing either craters or fissures.	Too high welding current. Inadequate welding force. Oxidised pieces to weld. Faulty pieces contact or pieces and electrodes faulty contact. Faulty pieces lining up. Electrodes tips deformations.	Reduce it. Increase welding pressure. Clean them by means of emery paper. Increase electrodes force. Correct their position. Restore them to the correct seize.
Pieces stuck weld on the electrode.	Too high welding current. Inadequate electrodes diameter. Inadequate welding force.	Reduce it. Restore it to the correct dimensions. Increase the welding pressure.

7 INSTRUCTIONS FOR THE ADJUSTMENTS

7.0 GENERAL INFORMATION

The reading of this chapter assumes, in order to safely use the welder, the knowledge of what stated in Chapter 1 Paragraph 4 "General Safety Warnings".

In addition, the specific prescriptions to safely interact with the welder, relevant to this chapter, are detailed in the following paragraphs.

7.1 STANDARD ACCESSORIES



The welder is supplied equipped with the following accessories:

- N° 1 Allen wrench set.
- N° 1 Electrodes extractor.
- N° 1 Pin driver 3 (for Item 3323).
- N° 1 Stroke adjustment key (for Items 3321 - 3322 - 3324 - 3327- 3328)
- N° 1 High conductivity grease sample.
- N° 1 Rotating supplementary handle
- N° 1 Filter-regulator pneumatic group with cutting device.
- N° 1 Welding control unit instruction manual.
- N° 1 Welder installation and use manual.
- N° 1 Technical documentation booklet.
- N° 1 Clips set, replacement screws and little accessories.

Check that the machine is complete with all the standard accessories; promptly inform the manufacturer of all the eventual missing parts.

7.2 MECHANICAL SET UP

7.2.1 ARMS SELECTION AND REPLACEMENT

OPERATOR QUALIFICATION	NUMBER OF OPERATORS	SAFETY MEASURES	WELDER STATUS
	1		 OFF

The lengthening of the arms causes a decreasing of the performances, so that it is advisable always to work with the shortest available length. Besides allowing obtaining better quality welds, this adjustment enables improving the machine's handling.

When carrying the arms replacement out, it is advisable to block all the welder's movements by means of the suitable brakes and to also block the balancer vertical stroke. This prevents the machine from moving because of the weight change.



The improper use of the balancer block device may involve serious risks. (Refer to the balancer instruction manual) Carefully read the balancer instruction manual and scrupulously follow its indications.

The operations to be followed for carrying the arms replacement out are reported here below.



ARMS REPLACEMENT IN THE "C" TYPE SUSPENDED WELDING GUNS ITEM 3323

The secondary surface increase causes a performances decrease. Therefore, it is always advisable to use those arms sets allowing the work to be done but having the smallest area. Besides allowing obtaining better quality welds, this adjustment enables improving the machine's handling.

When carrying the arms replacement out, it is advisable to block the welder vertical movement by means of the balancer block control. This prevents the machine from moving because of the weight change. **The improper use of the balancer block device may involve serious risks. (Refer to the balancer instruction manual) Carefully read the balancer instruction manual and scrupulously follow its indications.**



The arms sets and electrodes replacement must always be carried out while the water cutting valves P are closed and the machine front part faces downwards so to prevent the water from entering the welder.



In case of water entering the welder, immediately stop the electrical supply and proceed with both loss and water removal.

Replacement of the movable electrode-holder (C)

- 1 Stop the electrical supply at the main switch supplying the welder.
- 2 Close the pneumatic supply and discharge the remaining air. The cutting device supplied with the machine accomplishes this task.
- 3 Close and discharge the water from the welder cooling circuit.
- 4 Loosen the screws (M) and slightly rotate the lower arm (B).
- 5 Remove the insulating protection (D) after having removed the screws (u).
- 6 First loosen then remove the screws (g), remove the electrode-holder (C).
- 7 Carefully clean the contact surfaces of both the stem and the new electrode-holder.
- 8 Check that the gasket (i) and the electrode venue are not damaged (eventually, replace them).
- 9 Check that the tube bringing water to the electrode inside stops at 3÷5 mm from the bottom of the electrode hole. (If necessary, use a different cooling tube) as per the following pictures.
- 10 Spread a light veil of conductivity grease on the electrode-holder contact surface.
- 11 Fix the new electrode-holder with the screws (g), without forgetting the steel washers (h). Tighten with a pair of 12-13 Nm.
- 12 Reassemble the protection (D).
- 13 Correctly place the arm (B) again and tighten the screws (M) with a pair of 24÷26 Nm.

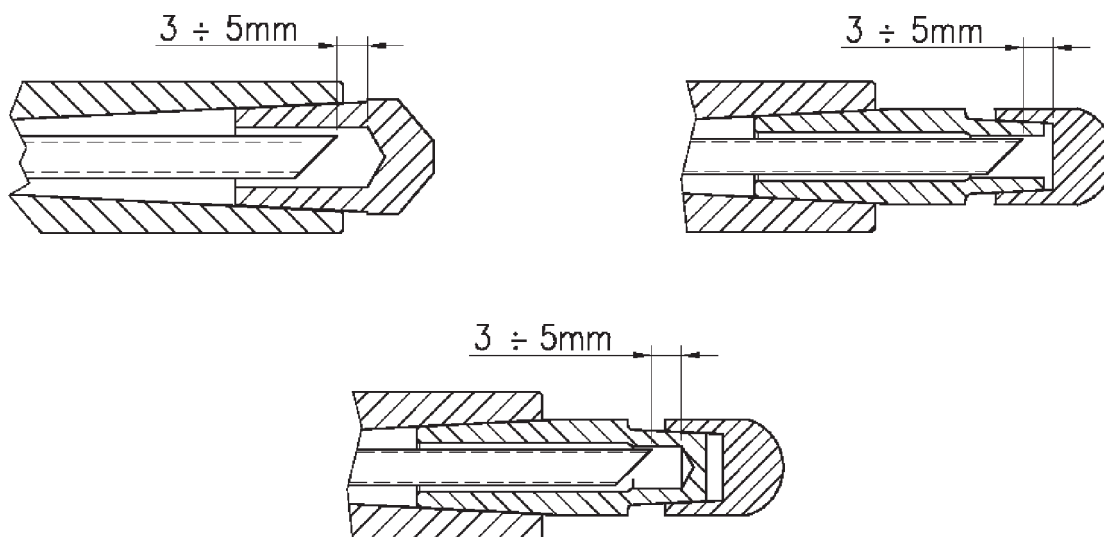

Replacement of the lower arm

- 1 Stop the electrical supply at the main switch supplying the welder.
- 2 Close the pneumatic supply and discharge the remaining air. The cutting device supplied with the machine accomplishes this task.
- 3 Close and discharge the water from the welder cooling circuit.
- 4 Loosen the screws (M).
- 5 By means of the pin driver standard supplied, rotate the ring-nut (J) as far as extracting the arm (B).
- 6 Carefully clean the venue and the end of the new arm.
- 7 Check that the gasket (n) and the conic venue of the electrode are not damaged.
- 8 Spread a light veil of conductivity grease on the end of the new arm.
- 9 Fit the new arm, caring to check the perfect entering of the tube "m" inside the cooling circuit, by rotating the ring-nut (J) as far as bringing the same to the necessary position (this operation allows adjusting the working stroke to the desired value).
Perfectly align the electrodes (A) and tighten the screws (M) with a pair of 24÷26 Nm.

After replacing the arm, it is necessary to adjust it (see paragraph 7.2.3 ARMS ADJUSTMENT)



Do not tighten the screws (M) if the arm is not fitted.

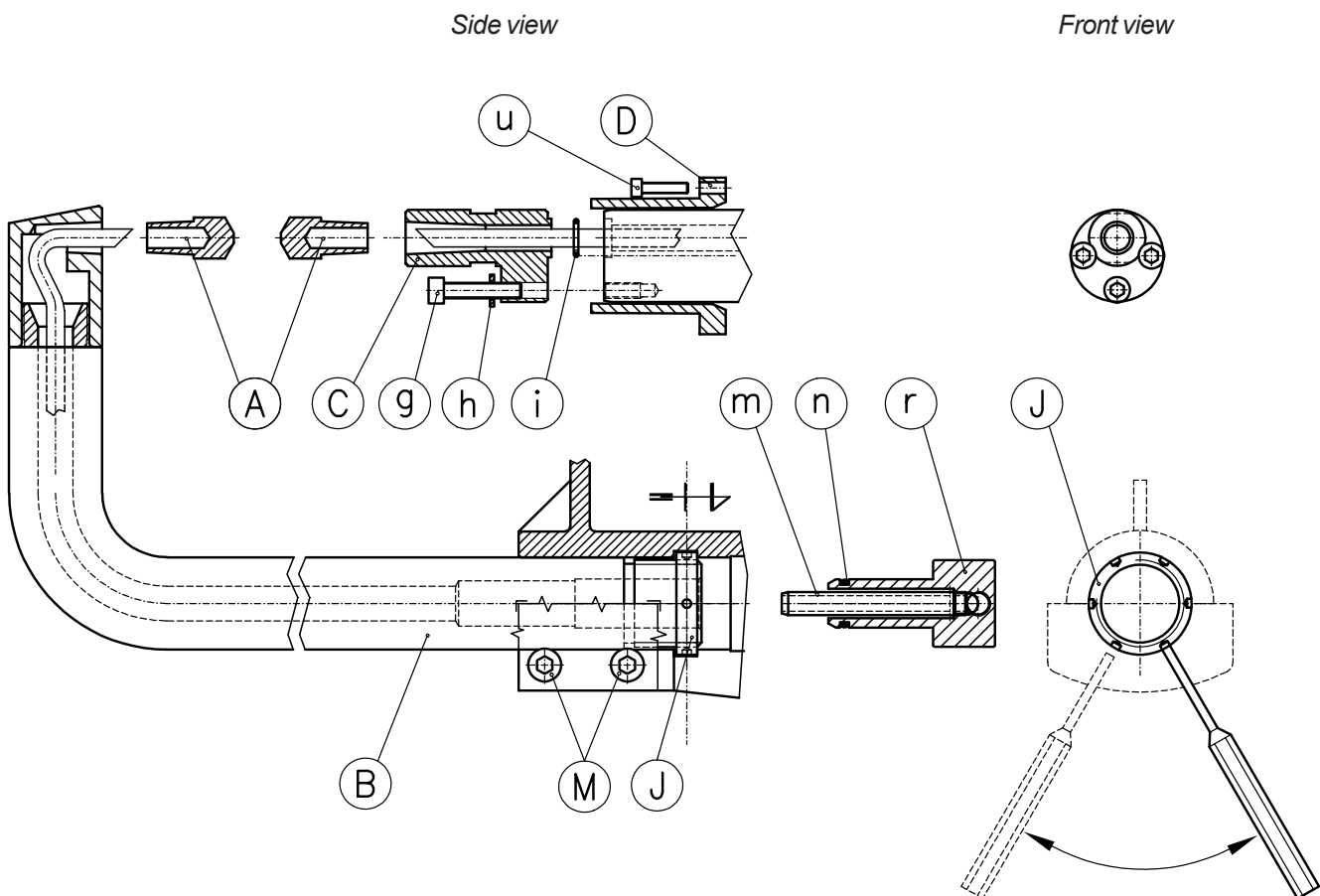



ARMS REPLACEMENT IN THE "L" TYPE SUSPENDED WELDING GUNS ITEM 3321 - 3322 - 3324 - 3327 - 3328

- 1 Stop the electrical supply at the main switch supplying the welder.
- 2 Close the pneumatic supply and discharge the remaining air. The cutting device supplied with the machine accomplishes this task.
- 3 Close and discharge the water from the welder cooling circuit.
- 4 Loosen the screws (M).
- 5 Remove the arms (A) without rotating them.
- 6 Carefully clean the venue and the end of the new arms
- 7 Fit the new arms (A). Pay careful attention to the complete fitting of the arms, as far as they are correctly placed in the reference working position.
- 8 Tighten the screws (M) with a pair of 12-13 Nm.





After replacing the arm, it is necessary to adjust it (see paragraph 7.2.3 ARMS ADJUSTMENT)

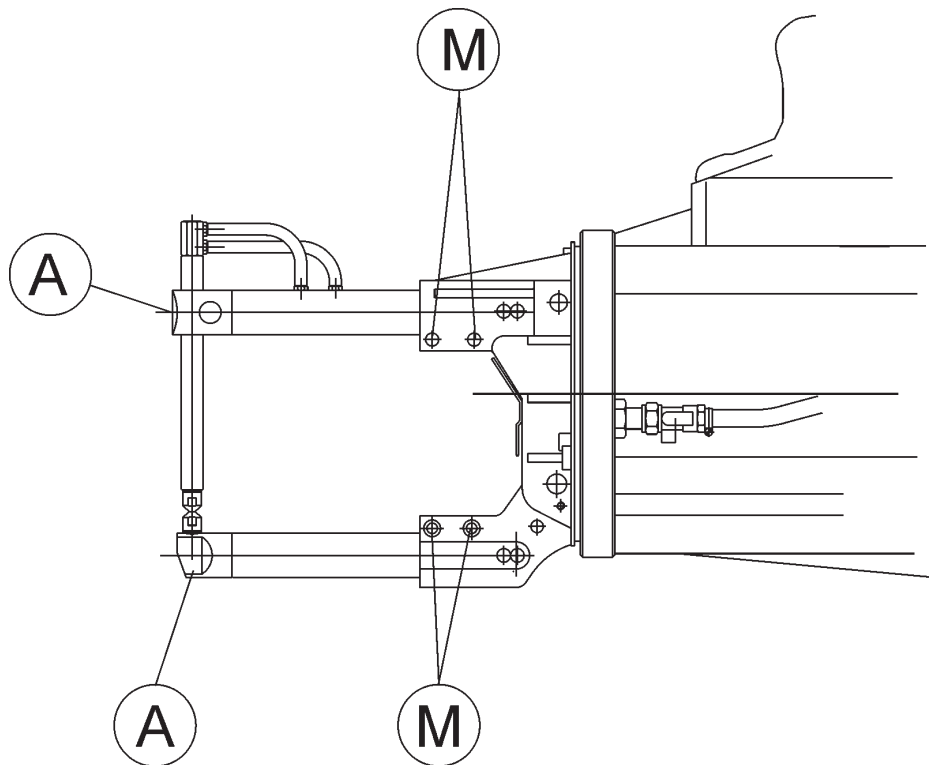

Do not tighten the screws (M) if the arm is not fitted.



7.2.2 SUSPENSION ADJUSTMENT

OPERATOR QUALIFICATION	NUMBER OF OPERATORS	SAFETY MEASURES	WELDER STATUS
	1	 	 OFF

The suspension adjustment is an operation allowing obtaining the greatest welder manoeuvrability in the working condition to be carried out.

Besides the adjustments on the welder, which are listed here as follows, it is necessary to carry the balancer adjustments out. For these operations, refer to the balancer instruction manual.

For allowing an easier adjustment, it is advisable to block the machine's vertical movement when carrying these adjustments out.

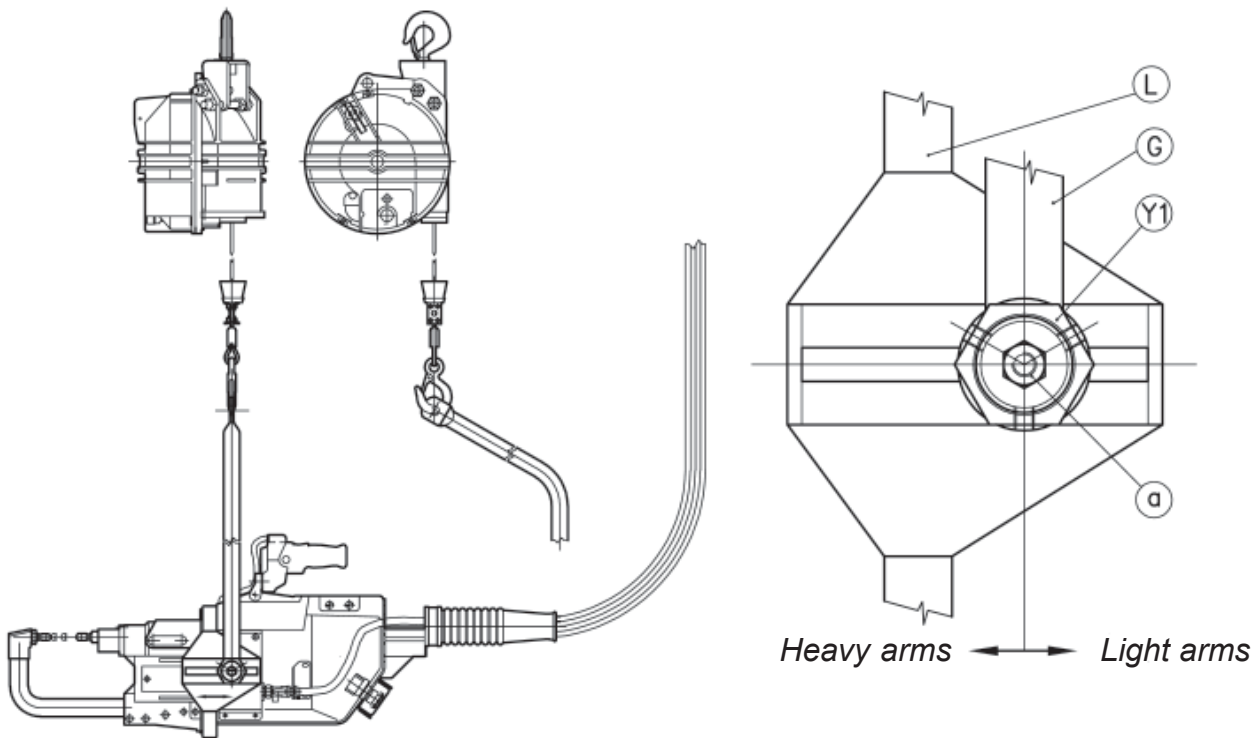
Longitudinal balancing

Example with welder item 3323

With the welder complete with its arms, one may carry the longitudinal balancing out by loosening the nut Y1 and by shifting the suspension arm on the guide as far as finding the point where the machine is balanced.

After the adjustment has been carried out, carefully tighten the nut Y1.

The safety nut (a) must never be loosened or removed so to avoid the machine's fall off in case the nut Y1 is accidentally unscrewed.

BRAKE ADJUSTMENT FOR THE TRAVERSE

By means of the three screws Y2, it is possible to adjust the gun's longitudinal rotation fluidity.

Art. Item 3321 - 3322 - 3323 - 3324

Art. Item 3327 - 3328

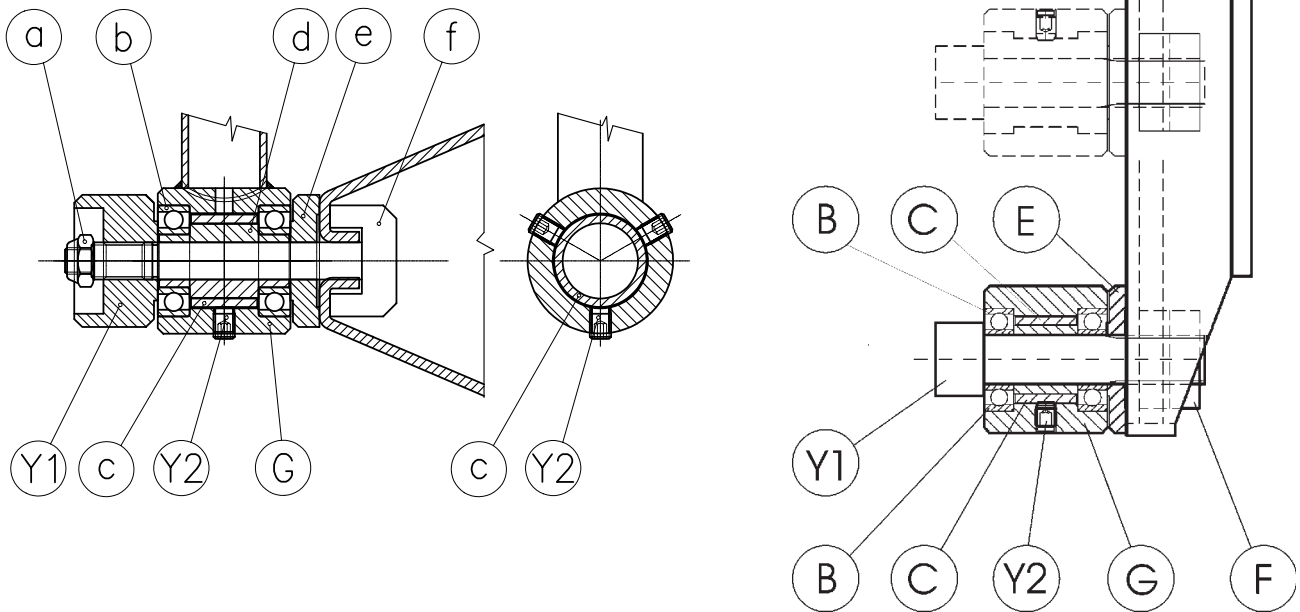

Dose the tightening force as far as obtaining the desired adjustment. The three screws must be tightened using a uniform force.

Do not exceed with the tightening force: this device has not been designed for carrying the traverse block out. An excessive tightening force could damage it.

GYROSCOPIC ROTATION BLOCK

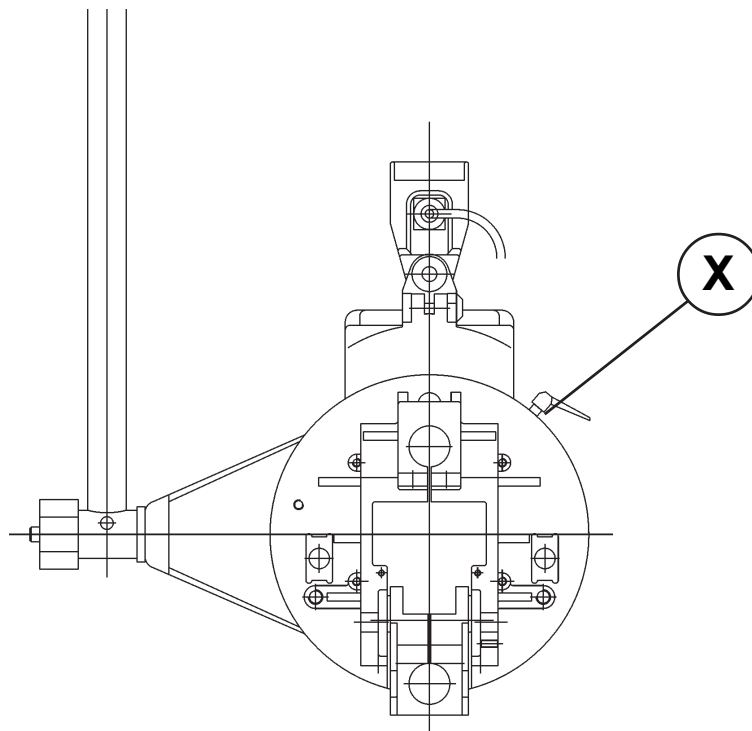

A threaded lever (x) placed on the gyrosopic ring of the welder allows blocking the welder's transversal rotation. This operation is useful for keeping the welder to the desired rotation angle. Simply, the block is obtained by tightening the threaded lever. Do not exceed with the tightening force so not to damage the rotation system.

7.2.3 ARMS ADJUSTMENT

OPERATOR QUALIFICATION	NUMBER OF OPERATORS	SAFETY MEASURES	WELDER STATUS
------------------------	---------------------	-----------------	---------------



1



ON

ADJUSTMENT IN THE "C" TYPE WELDERS ITEM 3323

Under working conditions, both arms and electrode-holders must be adjusted in order to have the electrodes tips coincide.

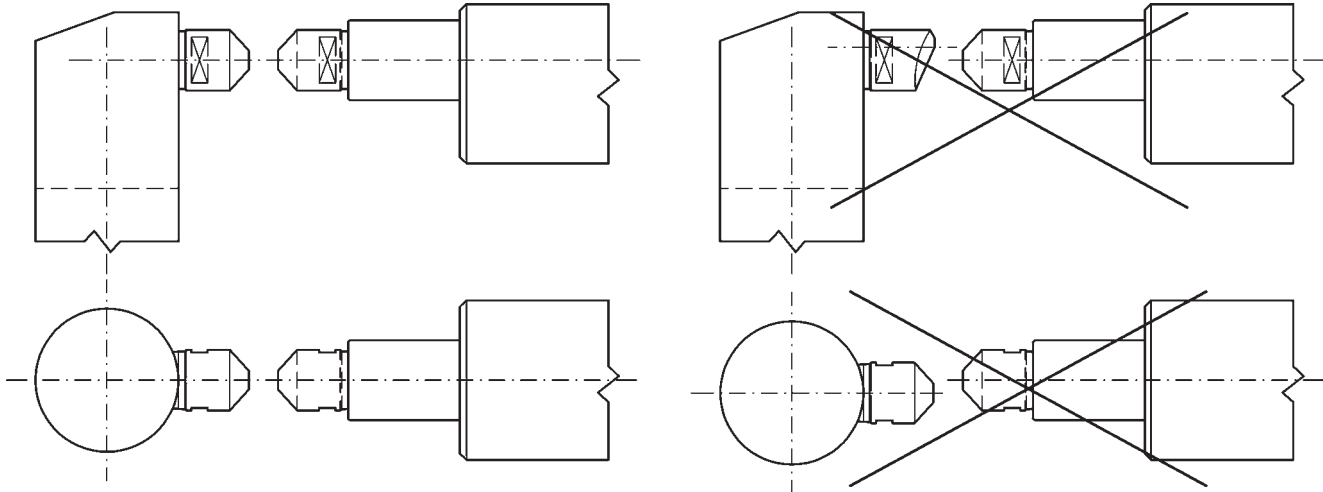

The adjustment is carried out by rotating the arm and, where foreseen, by carrying out the vertical alignment of the fixed electrode-holder. To rotate the arm:

- 1 Stop the electrical, pneumatic and the cooling water supply.
- 2 Loosen the screws (M) so to free the arm.
- 3 Rotate the arm so that the two electrodes are in axis.
- 4 Tighten the screws (M) with a pair of 24÷26 Nm.



This type of operations must be carried out when the machine is on; therefore one must operate using the maximum caution and carefulness.

Carry out some tests with the control unit on NO WELD mode, using the same electrodes force employed to carry out the work; place between electrodes a thickness equal to that which must be welded.

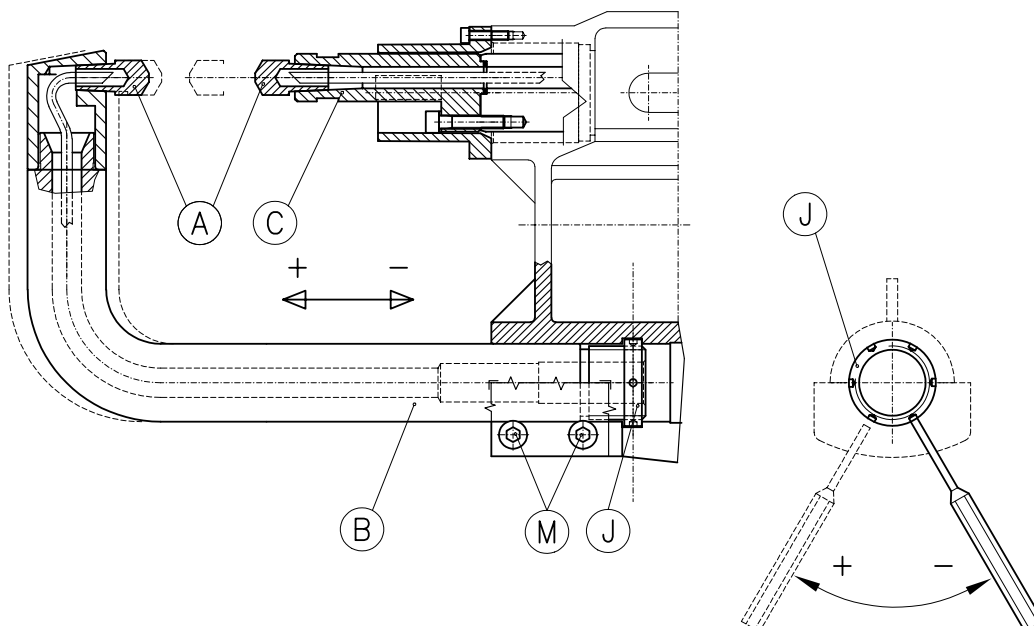

Do not tighten the screws (M) if the arm is not fitted.

ADJUSTMENT IN THE "L" TYPE WELDERS ITEMS 3321 - 3322 - 3324 - 3327 - 3328

Under working conditions, both arms and electrode-holders must be adjusted in order to have the electrodes tips coincide.

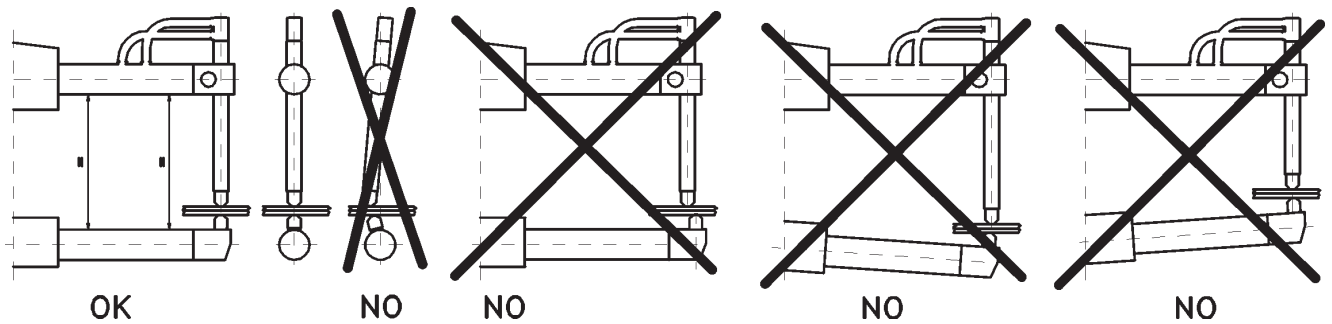

If necessary, it is possible to carry the adjustment out by moving the upper electrode-holder and/or the lower arm.

The lower arm may be shifted by carrying the following operations out:

- 1 Stop the electrical supply at the main switch supplying the welder.
- 2 Close the pneumatic supply and discharge the remaining air. The cutting device supplied with the machine accomplishes this task.
- 3 Close and discharge the water from the welder cooling circuit.
- 4 Loosen the screws (M).
- 5 Carry out the longitudinal adjustment of the arm.
- 6 Tighten the screws (M) with a pair of 24-26 Nm.
- 7 Carry out the arms parallelism adjustment by loosening the screw (C) and by placing between the electrodes a thickness equal to that which must be welded.
- 8 Tighten the screw (C) with a pair of 12-13 Nm.



This type of operations must be carried out when the machine is on; therefore one must operate using the maximum caution and carefulness.

Carry out some tests with the control unit on NO WELD mode, using the same electrodes force employed to carry out the work; place between the electrodes a thickness equal to that which must be welded.

It is of the utmost importance that the arm is properly fitted into the arm-holder.

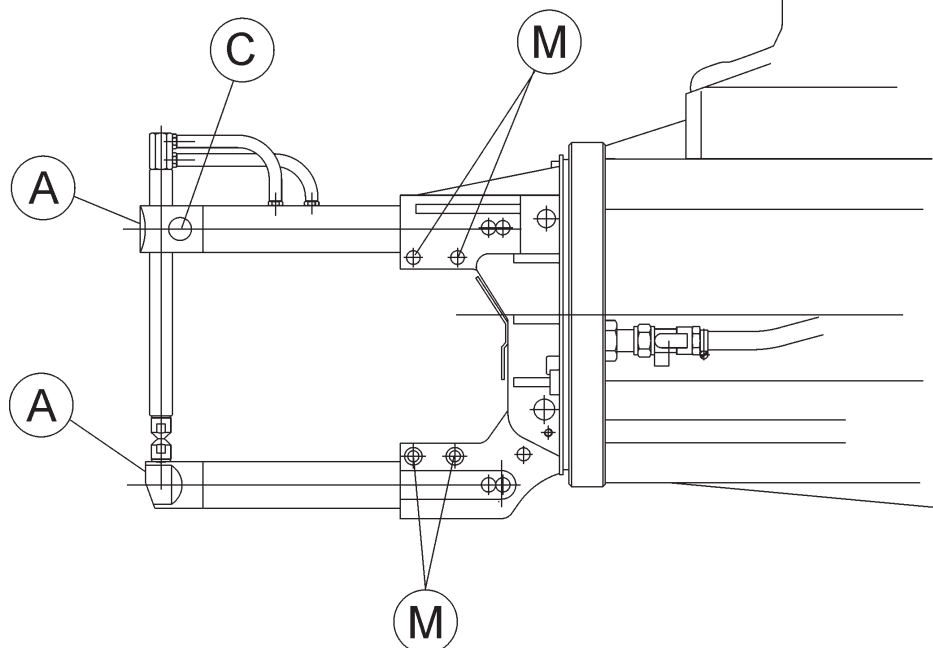

Do not tighten the screws (M) if the arm is not fitted.

7.2.4 ELECTRODES ADJUSTMENT

OPERATORQUALIFICATION	NUMBEROFOPERATORS	SAFETYMEASURES	WELDERSTATUS
-----------------------	-------------------	----------------	--------------



1



OFF

The electrodes replacement must be carried out so not to damage the electrode-holder cone.

The electrode extraction may be carried out by means of either a key or the suitable extractor supplied with the standard accessories.

To facilitate the electrode removal and to prevent from taper seizure spread a light veil of high conductivity grease on the cone. This procedure is mainly advisable when the cone has extremely reduced angles.

It is possible to extract the electrode in two different ways:

1 Extraction by axial movement

By using the extractor supplied with the standard accessories, it is possible to apply an axial force with the extractor prizing between the electrode and the electrode-holder.

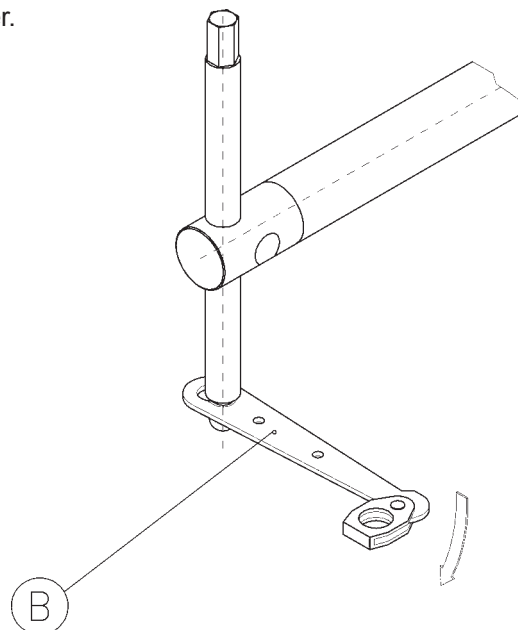
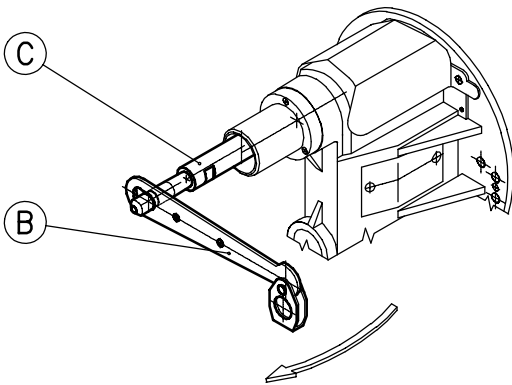

2 Extraction by rotating movement

By either using the extractor supplied with the standard accessories or a key, apply a rotating force.

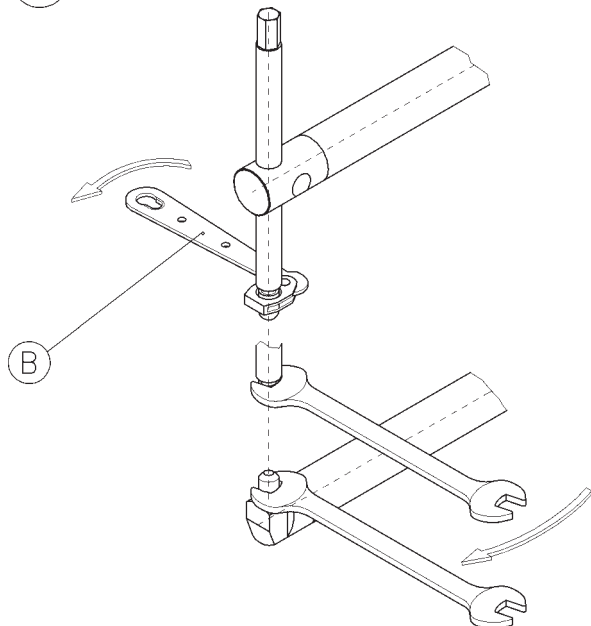
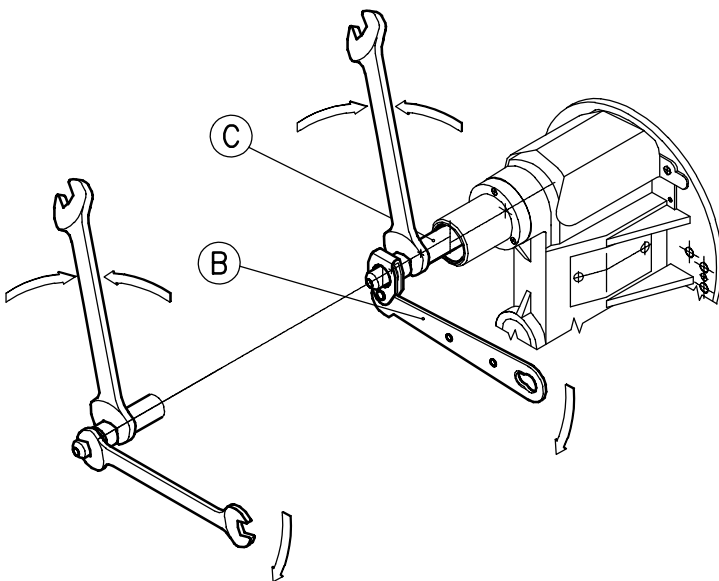

1 - Extraction by axial movement

2 - Extraction by rotating movement

In the "C" type welders item 3323, one must pay attention to force neither the electrode-holder nor the cylinder. If the electrode is extracted by rotating movement, do support the effort with a key fitted on the electrode-holder C.



This type of operations must be carried out when the machine is on; therefore one must operate using the maximum caution and carefulness.

To prevent from cooling water leakage when the machine is off, close the circuit delivery taps placed on board the machine.

It is advisable to adjust the electrodes with a fine file or with sandpaper. The best performances can be reached by using sand paper folded upon a support having the same thickness of the sheets to be welded.

The diameter of the electrodes must be adjusted to a value suitable for the welding to be carried out. The sheets thickness, the kind of material and the chosen welding class must be taken into account. The following values are suggested when welding steel:

SHEETS THICKNESS	mm	0,5	0,8	1	1,5	2	2,5	3	3,5	4
ELECTRODE DIAMETER	mm	4	4,5	5	6	7	7,5	8,5	9,5	11

The suggested electrode tip angle is 120 degrees. If the thickness of the two plates is different the electrode must have the diameter corresponding to the one required by the plate to which it gets in touch.

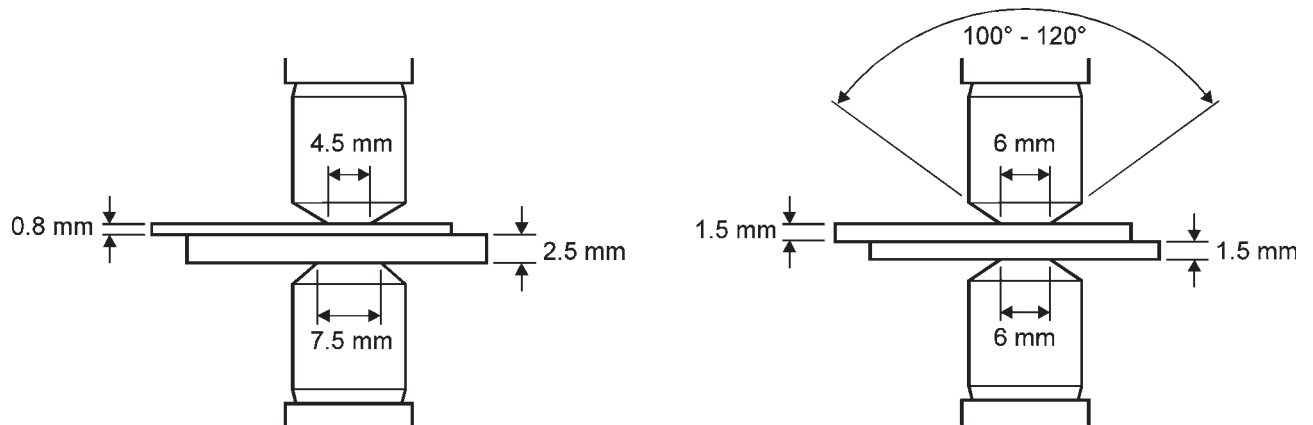



A too small diameter in comparison with the thickness to be welded produces spatters of melted material, excessive mark on the sheets, low spot quality. If the electrode's diameter is too large, longer welding times are necessary, causing a higher heating of the welder and a shorter life of the electrodes.

Besides the truncated-conic electrodes, other electrodes types may be used like, for instance, spherical, rounded, flat-tipped ones, etc.

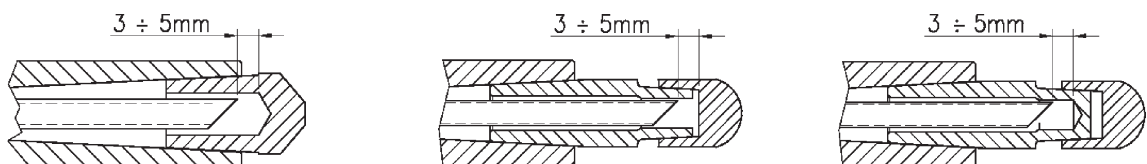
For all electrodes types, do evaluate the proper electrode cooling.



7.2.5 WORKING STROKE ADJUSTMENT

OPERATOR QUALIFICATION	NUMBER OF OPERATORS	SAFETY MEASURES	WELDER STATUS
	1		OFF

Adjust the working stroke to the minimum possible value to obtain.

- 1 Reduced accident possibilities.
- 2 Reduced noise.
- 3 Bigger productivity.
- 4 Faster force rise time on the pieces to be welded.
- 5 Higher follow up.
- 6 Higher working precision.
- 7 Reduced air consumption.

The stroke adjustment must be carried out in order to avoid that the cylinder reaches the end of the stroke, limiting or clearing, by doing so, the force on the piece. Remind that both electrodes wear and arms deflection increase the working stroke.



ADJUSTMENT IN THE "C" TYPE WELDERS ITEM 3323

The working stroke may be modified by shifting the lower arm; carry the following operations out:

- 1 Stop the electrical, pneumatic and the cooling water supply.
- 2 Loosen the screws (M).
- 3 Adjust the working stroke by rotating the ring-nut (J) by means of the pin driver supplied with the standard accessories.
- 4 Perfectly align the electrodes (A).
- 5 Tighten the screws (M) with a pair of 24÷26 Nm.



This type of operations must be carried out when the machine is on; therefore one must operate using the maximum caution and carefulness.

Carry out some tests with the control unit on NO WELD mode, using the same electrodes force employed to carry out the work; place between the electrodes a thickness equal to that which must be welded.



Do not tighten the screws (M) if the arm is not fitted.

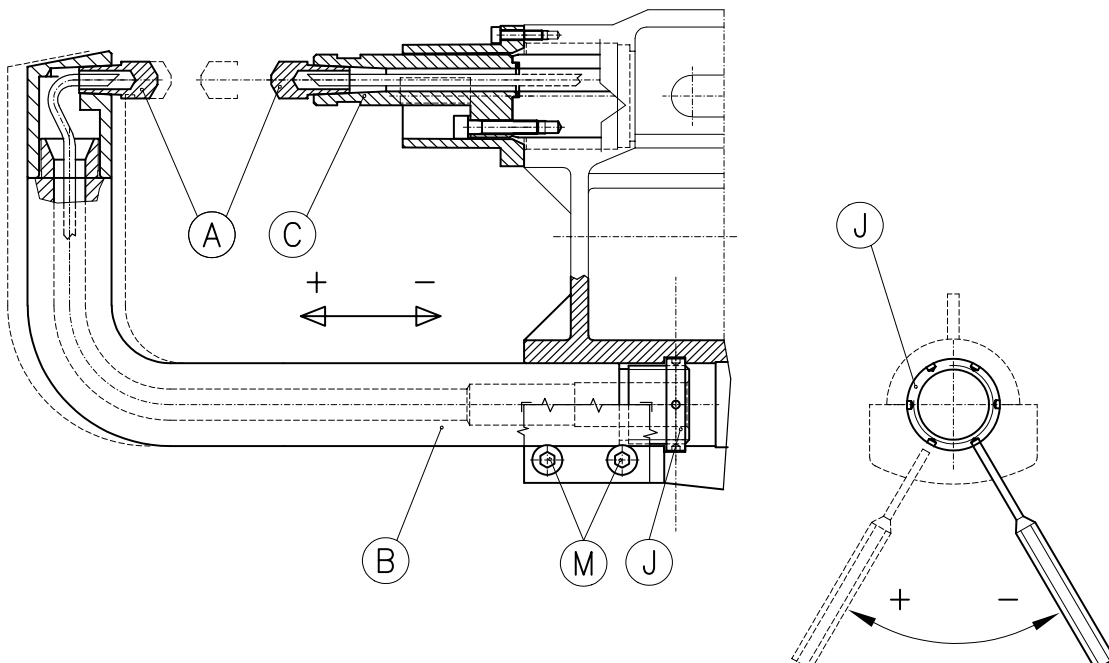



ADJUSTMENT IN THE "L" TYPE WELDERS ITEMS 3321 - 3322 - 3324 - 3327 - 3328

Before adjusting the working stroke check that the arms, when clenching the pieces to be welded, are parallel. This operation must be carried out when having the stroke selection trigger on short stroke.

The working stroke adjustment is carried out by proceeding with the following operations:

- 1 Stop the electrical, pneumatic and the cooling water supply.
- 2 Loosen the ring-nut B with the key A.
- 3 Rotate the screw C with the 5 mm Allen spanner D for adjusting the working stroke.
- 4 Once the adjustment is done, tighten the ring-nut B again.



This type of operations must be carried out when the machine is on; therefore one must operate using the maximum caution and carefulness.

Carry out some tests with the control unit on NO WELD mode, using the same electrodes force employed to carry out the work; place between the electrodes a thickness equal to that which must be welded.



When adjusting the stroke, pay attention that the machine's movable lever **DOES NOT** touch the suspension gyroscopic ring when operating in long working stroke condition.

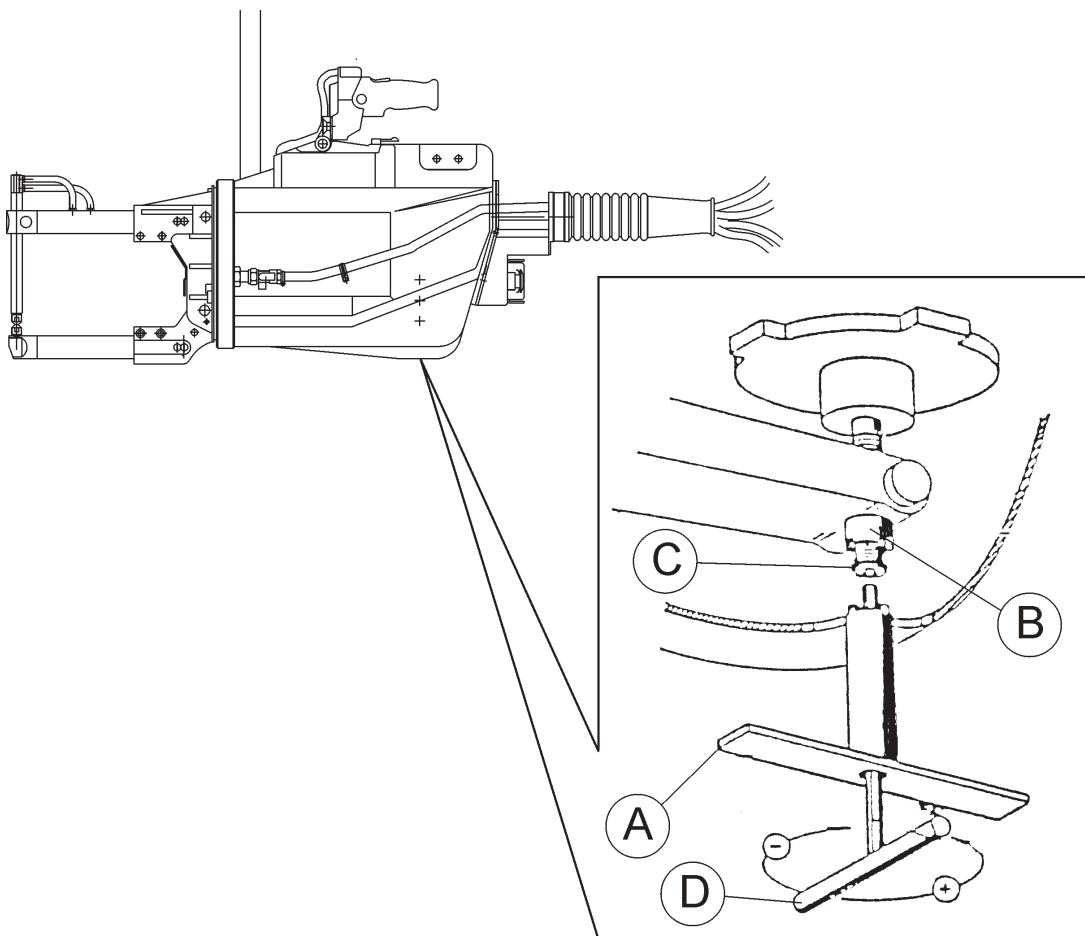

7.2.6 DOUBLE STROKE USE

All the welders are equipped with the "double stroke" that is to say a device enabling using two different strokes of the electrodes: the short stroke (or working stroke) and the long stroke (or full stroke).

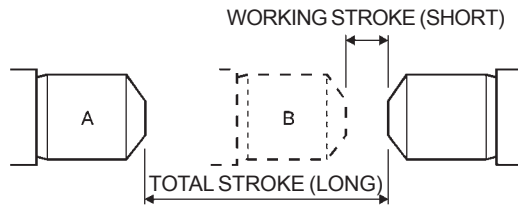

A – MOBILE ELECTRODE POSITION WITH DISABLED DOUBLE STROKE (LONG STROKE)
 B – MOBILE ELECTRODE POSITION WITH ACTIVATED DOUBLE STROKE (SHORT STROKE)

This function may be used for two different purposes:

1 *Overcome the obstacles*

When spot welding pieces of great dimensions, it would be necessary to have a high stroke to allow placing the pieces between the electrodes. To allow using a reduced stroke in this working condition too, the machine may be used with the "double stroke". In normal conditions, one works with the short stroke and, when necessary, one may temporarily open the machine for overcoming the obstacle.

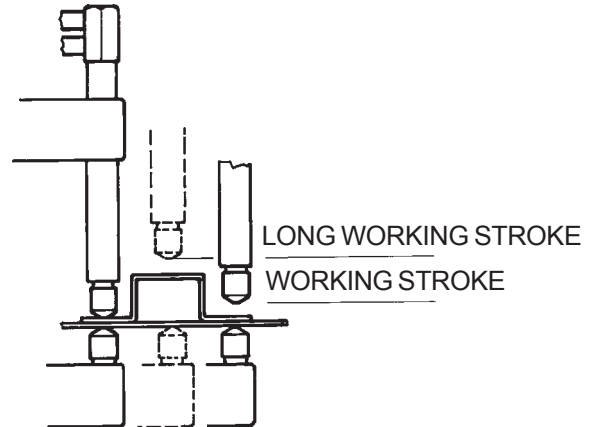
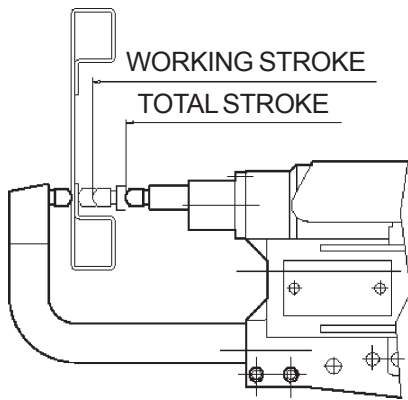



2 *Replacement of the electrodes*

By using a reduced working stroke the replacement of the electrodes may become a problem. The "double stroke" function enables opening the electrodes to easily remove them.

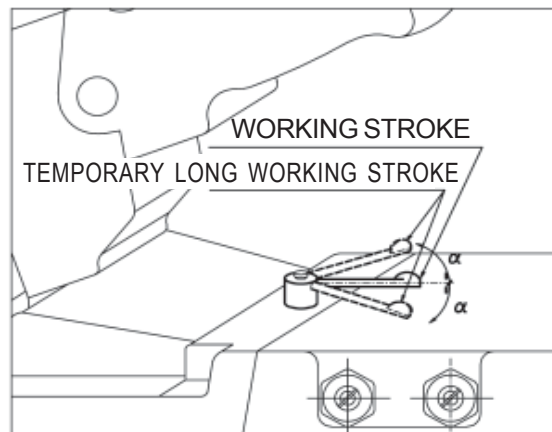
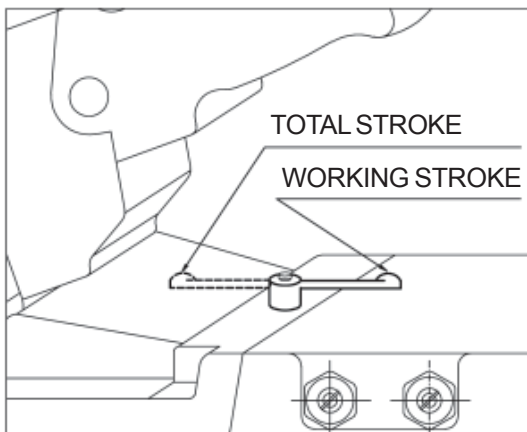
The double stroke is controlled by a selector placed underneath the handle. With the selector rotated in the front position, the short stroke is obtained. By rotating the selector in the back fixed position, the long stroke is selected. By simply carrying out a little rotation of the selector, it is possible to obtain the temporary long working stroke which is useful for overcoming the obstacles.



7.3 ELECTRODE FORCE ADJUSTMENT

OPERATOR QUALIFICATION	NUMBER OF OPERATORS	SAFETY MEASURES	WELDER STATUS
	1		NO WELD

The welding force must be selected taking into consideration both tables and personal experience, and in relation to the sheets thickness, the desired spot quality, etc.



Always adjust by keeping the welding control unit on "NO WELD" in order to avoid any risk caused by a wrong adjustment. Always carry out "NO WELD" cycle tests before starting the welding process.

An excessive electrodes force can cause:

- welding over marks;
- possible electrodes short life;
- weak welding or false welding due to a reduction of the contact resistance, which allows the current to pass through without bringing the piece to the melting temperature.

An insufficient force on electrodes can cause:

- spatters of melted material;
- stuck weld of the pieces on the electrode;
- welding with a disagreeable outside surface.

If the welding to be carried out requires low or precise force values, it is advisable to verify the adjusted force by means of a dynamometer.

The electrodes force adjustment is carried out by means of the pressure regulator placed on the welder supply. The supply pressure variation, displayed by the relevant pressure gauge, modifies the welding force. The reached force values, concerning the different pressure values showed on the pressure gauge, are listed in the following tables.

	L	F	Arms weight (pair)	Short stroke		Long stroke	
	mm	daN	Kg	min. mm	max mm	min. mm	max mm
Art, Item 3321	190	286	3,3	6	25	30	48
	250	227	4,3	7	30	38	60
	350	168	5,8	10	41	50	80
	508	120	8,5	13	56	70	112
	650	95	10,6	18	72	90	140

	mm	daN	Kg	min. mm	max mm	min. mm	max mm
	Art, Item 3322	190	338	3,3	5	20	28
250		268	4,3	6	25	35	50
350		199	5,8	8	34	47	70
508		120	8,5	13	56	70	112
650		113	10,6	15	60	84	120
800		93	13	18	73	102	146

	mm	daN	Kg	min. mm	max mm	min. mm	max mm
	Art, Item 3324	250	268	4,5	6	25	35
350		199	6	8	34	47	70
508		140	8,7	12	48	65	97
650		113	10,8	15	60	84	120

Art, Item 3327	L	F	Arms weight (pair)	Short stroke		Long stroke	
	mm	daN	Kg	min. mm	max mm	min. mm	max mm
	255	695	6,5	10	26	45	60
	408	386	9,5	12	35	65	75
	610	264	13,5	22	60	100	136
	820	196	18	30	75	130	175
	1030	156	22	40	100	165	225

Art, Item 3328	mm	daN	Kg	min. mm	max mm	min. mm	max mm
		255	695	7	10	26	45
	408	386	10	12	35	65	75
	610	264	14	22	60	100	136
	820	196	18	30	75	130	175

Art, Item 3323	L	F	Arms weight (pair)	Short stroke		Long stroke	
	Art. Item	daN	Kg	min. mm	max mm	min. mm	max mm
	4883	300	3,2	5	20	35	50
	4882						
	4884	300	3,9	5	20	35	50
	4882						

F = Force at the electrodes at a 600 kP (6 bar)

By means of two flow regulators, it is possible to adjust the electrodes opening (V) and closing (Z) speeds. The adjustment is carried out by means of a screwdriver.

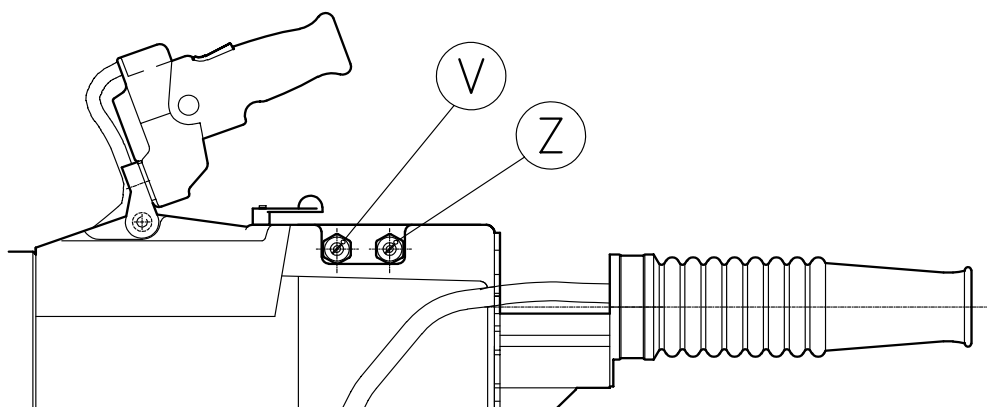

Be aware that a too slow electrodes clamping speed adjustment can cause either an insufficient force at the electrodes at the welding start or a welding start occurring before the contact if the squeeze time is too slow.

7.4 WORKING PROGRAM ADJUSTMENT

This operation enables to choose the welding parameters and to enter them directly on the welding control. Select parameters from table or personal experience, taking into consideration the plate thickness, the welding desired quality etc.

We suggest using short welding times to reduce the electrodes heating, thus increasing their life, at the same time avoiding oxidation on the contact surfaces.

The best quality welds are obtained by using welding times as short as possible with high current and high electrode force.

Notice that when operating pieces with different thickness, the welding parameters to be used are those which refer to the lower thickness.

This welder can operate under two different working modes: single cycle and automatic cycle. The adjustment instructions are stated on the welding control unit instruction manual. When working in automatic cycle, as long as the start-cycle control device is activated, the welder will repeat welding cycles at the settled off time. In single cycle, even though the start device is kept activated, the welding unit will stop after having carried out a single cycle; to carry out the next one, it is necessary first to release the device and then press it once again.



To avoid any danger, use the automatic cycle only when it is really necessary; it must not be activated when it is not used.

Adjust SQUEEZE time at a value high enough to enable the electrodes to reach the pieces to be welded, as well as the chosen force, before the welding current is activated, especially in case of long stroke or reduced speeds.

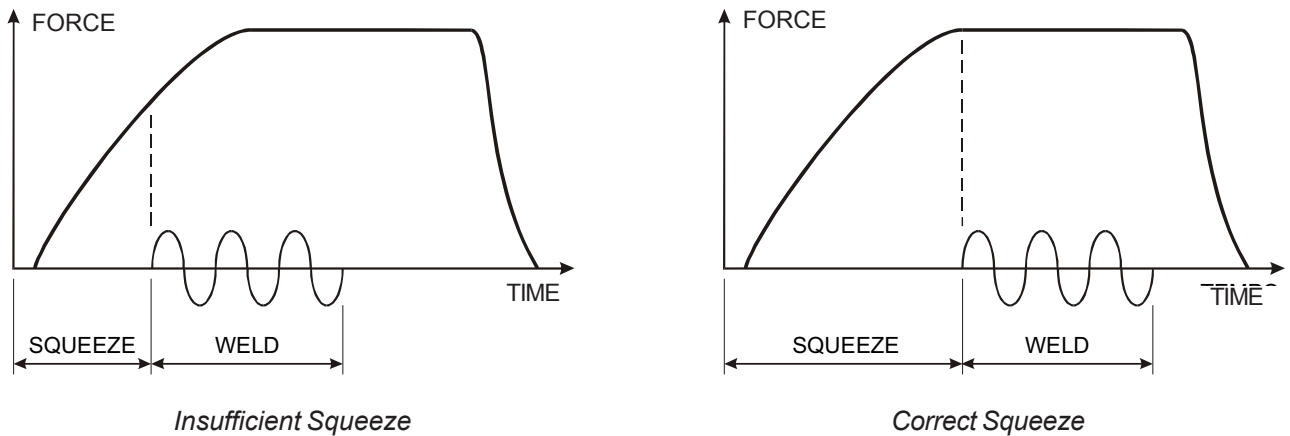

When the welding time is over, the electrodes must be kept closed for a few moments; the elapsing time is called HOLD time. This precaution enables to improve the weld quality. We recommend setting this parameter to a value corresponding to the half of the one chosen for the welding time.



8 MAINTENANCE

8.0 GENERAL INFORMATION

The reading of this chapter assumes, in order to safely use the welder, the knowledge of what stated in Chapter 1 Paragraph 4 "General Safety Warnings".

In addition, the specific prescriptions to safely interact with the welder, relevant to this chapter, are detailed in the following paragraphs.

8.1 ORDINARY MAINTENANCE

OPERATOR QUALIFICATION	NUMBER OF OPERATORS
	1
SAFETY MEASURES	WELDER STATUS
	 OFF

This chapter states the necessary maintenance operations to be carried out for:

- 1 keeping the welding unit safe operating and preserving its efficiency;
- 2 avoiding the most common causes of wrong working worsening the welding quality.



During the maintenance operations it is advisable to block the balancer (for further information, check the balancer instruction manual).



We remind that, besides carrying the machine maintenance operations out, it is necessary to carry the balancer maintenance out by following the instructions included in the relevant instruction manual.

For all interventions involving disassembling the machine, kindly, refer to the exploded views showing the parts and their position. We recommend maximum cleaning, oxidations removal, use of lubricants and prescribed products.

LUBRICANTS

The suggested lubricants for the welder are listed in the technical documentation.

- POLIMER 400 GREASE or equivalent
- MOLIKOTE "G-N PLUS" GREASE
- VANOFRIX 430 CONDUCTIVITY GREASE or equivalent (remove the exceeding grease after tightening the parts so to prevent from short-circuits)
- MINERAL or SYNTHETIC OIL with MOLIKOTE "M 55 PLUS" additive at 10%.

GENERAL WARNINGS



Always disconnect both electrical and pneumatic supply before carrying out the following maintenance operations.

- The secondary circuit contacts must be kept clean. Fine sandpaper can be used for cleaning. After cleaning, apply a light veil of conductivity grease on the contact parts. Once the parts are assembled, remove the exceeding grease so to prevent from short-circuits
- Always keep the screws of arms, electrode-holders, and rigid/flexible connections well tightened.
- Periodically (each 3 months), grease the gyroscopic ring venue by means of the proper greaser placed on the ring itself. Carefully, remove the exceeding grease.
- Check that the flexible connection is undamaged. Eventual broken laminates must be removed so to prevent them from causing short-circuits. If the flexible connection is excessively worn out, replace it.
- Keep welder clean from dirt and metal scraps attracted by the magnetic field generated by the welder during the operation.
- Neither washing the welding unit with jets of water which could enter it, nor use strong solvents, thinner, nor benzene that could damage either the painting or the machine plastic components.

ELECTRODES MAINTENANCE



Electrodes maintenance must be carried out with the welder switched off.

- When operating, the electrodes must be kept clean and their diameter must be kept suitable for the work to be carried out. Too worn electrodes must be replaced.
- When replacing electrodes, check that the tube bringing water to the electrode inside stops at a few mm from the bottom of the electrode hole.
- Do not use sealing products to remove water leakage on the electrode taper. To facilitate the electrode removal and to prevent from both taper seizure and leakage, use high conductivity grease like the one delivered in the standard equipment.
- Before replacing the electrodes, stop the water supply circuit or stop the electrodes cooling circuit by means of the valves placed on the welder side.



WARNING! Before starting the production again, always check that the cooling circuit has been reopened.

PNEUMATIC CIRCUIT MAINTENANCE



The pneumatic circuit maintenance must be carried out by specialised personnel only, trained to accomplish it under safety conditions. When possible, maintenance operations must be carried out with the welder switched off and disconnected from the pneumatic supply, with the circuit free from left air.

- In case of air leakage, immediately stop operating and remove it.
- Check the proper functioning of the automatic air filter discharge.
- Check pressure gauge calibration.
- Check the status of both compressed air and corresponding connections.
- Watch out not to introduce either dirt or dust in the machine which may cause serious damages, stop or quick wear.

COOLING CIRCUIT MAINTENANCE



The cooling circuit maintenance must be carried out by specialised personnel only, trained to accomplish it under safety conditions. When possible, maintenance operations must be carried out with the welder disconnected from both electric and pneumatic supply.

- Check that cooling water circulates freely and in the required quantity, and that the input temperature is included within 10 and 30°C.
- Check the status of both water hoses and the corresponding connections.
- **If, during the winter terms, the welder must be stored up in cool rooms, it is necessary to carefully drain the cooling circuit to prevent from possible damages caused by frozen water.**

ELECTRIC CIRCUIT MAINTENANCE



The electric circuit maintenance must be carried out only by specialised personnel trained to accomplish it under safety conditions. Disconnect electric mains before carrying out the following instructions as mortal discharges may be received from the supply.

- Frequently, check the welder supply cable status. Pay special attention to the points where the cable gets mainly stressed or exposed to possible mechanical damages. Replace it in case cracks, cuts, heavy abrasions are found.
- Check that the welder is connected to the protection conductor, that the ground wire inside the supply cable is not cut.
- Periodically check the ground efficiency.

- Often check both the status and the proper functioning of the control devices and of the corresponding connecting cables.
- Frequently check the proper functioning of the earth leakage circuit breaker by means of the relevant test button.
- Frequently check the proper functioning of the earth leakage circuit breaker which must be installed on the supply mains and of the other eventual protection devices.

8.2 EXTRAORDINARY MAINTENANCE

OPERATORSKILLS	NUMBEROFOPERATORS
	1
SAFETY MEASURES	WELDER STATUS



This chapter states the maintenance operations to be carried out in case of:

- 1 lowering of the welder performances;
- 2 welder wrong operating;
- 3 welding faults.

8.2.1 LOWERING OF THE WELDING UNIT PERFORMANCES



Extraordinary maintenance must be carried out by specialised personnel only, equipped with the proper instruments and trained to accomplish it under safety conditions. When possible, the welder must be disconnected from both pneumatic and electric supply.

If the performances are lower than expected, check:

- That, when welding, line voltage drop is lower than 15%.
- That the supply cables section is adequate.
- That the electrodes diameter is appropriate for the work to be carried out.
- That cooling water circulates in the required quantity.
- That the welding pressure shown by the pressure gauge is adequate for the work in process.
- That the pressure gauge works properly.

8.2.2 REPAIR OR REPLACEMENT OF THE SUPPLY CABLE

The supply cable is often subject to heavy mechanical stress which may cause damages. The occurred damage may involve both the cable interruption and short-circuit.

Remember that the cable interruption may also be limited to the protection conductor only. For this reason, it is of the utmost importance that some standard maintenance is carried on the cable out so to periodically check the continuity of the protection circuit.

Should the cable got damaged because of short-circuit, please, remember that the earth leakage circuit breaker would immediately open. In this case, the switch may get damaged and it would, therefore, be necessary to replace it.

The cable maintenance may also be preventative should the machine stop-over caused by this potential damage be too burdensome.

Carry the intervention out by opening the **R1** connection box. Dependently on the general wear status of the cable, on the breaking point distance from the machine and on the availability of a cable sufficient length for carrying the repair out, one may either integrally replace the cable or repair the same by shortening its length.

The necessary operations for carrying the intervention out are described here below.



Stop the electric, pneumatic and cooling supply so that NOBODY CAN SUPPLY THE WELDER BEFORE HAVING COMPLETED AND CHECKED THE INTERVENTION.

- A) Open up the lid 51 of the cable connection box by removing the nut 38 and the screws 56.
- B) Unscrew the nut 52 and the two screws 55; remove the 3 washers 53 and the cable 30.
- C) Identify the position in the cable 30 where the damage occurred.

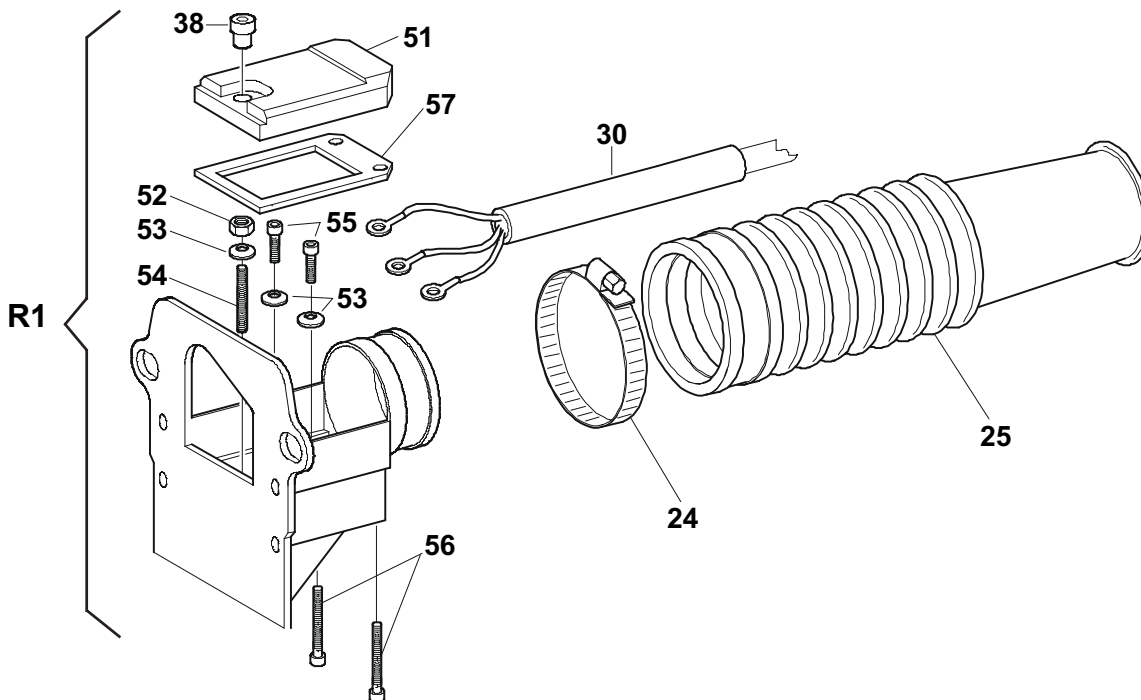

If the circumstances allow it, repair the cable, otherwise replace it.

Cable repair

- D) Cut the cable 30, 10 cm beyond the breaking point.
- E) Arrange the cable as per the following drawing. The cable diameter L must be perfectly cylindrically restored by means of self-agglomerating tape or similar one. Follow the tape manufacturer's instructions.

Cable replacement

- D) Open the switch box and remove the cable 30.
- E) Check that the replacement cable is the correct one for the machine and connect it to the switch.

- F) Reassemble the cable by tightening the 3 cable lugs with the 2 screws 55 and the nut 52 with a suitable tightening pair.
- G) Check the perfect work execution: distances as per drawing; painstaking insulating; well-tightened screws; free-to-move cable in a position not to undergo any stress.
- H) Reassemble the lid 51 of the cable connection box by tightening the nut 38 and the screws 56. Possibly, reassemble a new gasket 57.
- I) Supply the welder again as follows: 1) open the cooling circuit and check eventual water leaks; 2) supply the compressed air; 3) supply the machine by activating the supply switch.
- J) Start the welder as suggested in the instruction manual for commissioning.

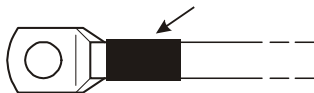
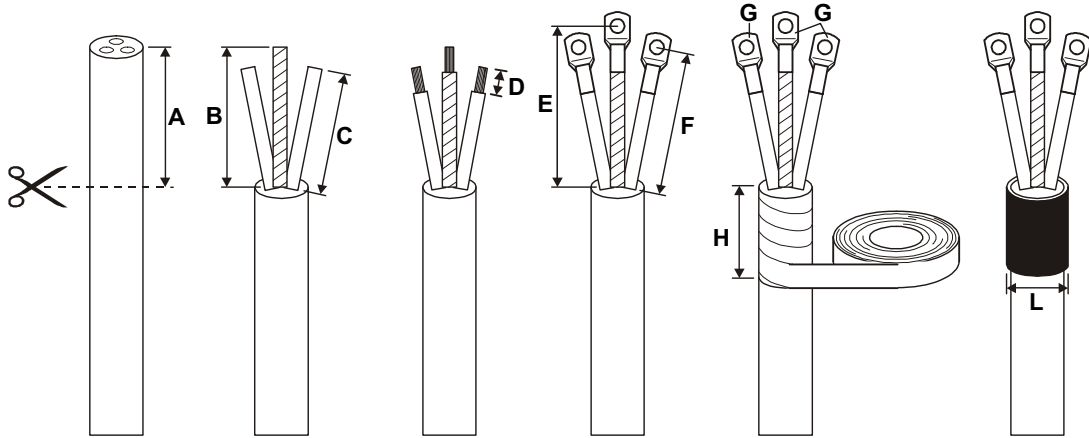

Insulate the lug joint with a thermo-shrinking sheath or some adhesive tape.

CABLE TYPE	A mm	B mm	C mm	D mm	E mm	F mm	G part number	H mm	L mm
3G6	35	35	20	8	46	31	A1-M6	35	25
3G10	35	35	20	9	48	33	A2-M6	35	25

9 SUPPLEMENTARY INSTRUCTIONS

9.0 GENERAL INFORMATION

The reading of this chapter assumes, in order to safely use the welder, the knowledge of what stated in Chapter 1 Paragraph 4 "General Safety Warnings".

In addition, the specific prescriptions to safely interact with the welder, relevant to this chapter, are detailed in the following paragraphs.

9.1 WASTE DISPOSAL

It will be care of the user, in accordance with the relevant laws in force in his country, to check the proper disposal of the waste produced by the machine during the specific production.

Furthermore, he will have to manage the disposal for greases, cooling liquids, etc. which are used in the machine for allowing its functionality.

If the user complies with the manufacturer's directives in its most significant parts, he will obtain an improvement of the equipment functionality together with an eventual improvement of the production itself.

9.2 OFF DUTY EQUIPMENT AND DISMANTLING

The machine is composed of the following materials:

- STEEL
- PLASTIC MATERIALS (PLEXIGLASS - TEFLON - DERLIN - POLIZENE)
- ELECTRIC COMPONENTS
- LUBRICATING GREASE
- COOLING LIQUIDS

FOR THE MACHINE DISMANTLING SCRUPULOUSLY COMPLY WITH THE INDICATIONS PROVIDED BY THE LAWS IN FORCE IN ONE'S COUNTY.

9.3 EMERGENCY CONDITIONS INSTRUCTIONS

IN CASE OF FIRE DO EXCLUSIVELY USE POWDER OR CARBON DIOXIDE EXTINGUISHERS.

10 ENCLOSURES

10.0 GENERAL INFORMATION

The reading of this chapter assumes, in order to safely use the welder, the knowledge of what stated in Chapter 1 Paragraph 4 "General Safety Warnings".

In addition, the specific prescriptions to safely interact with the welder, relevant to this chapter, are detailed in the following paragraphs.

10.1 ACCESSORIES AND SPARE PARTS REQUEST

When ordering accessories, spare parts or expendable material, please, always state: type of machine, year of manufacture, serial number, the voltage and frequency of the welder they must be assembled on.

Look at the exploded views and at the spare parts list to identify the item number of the required parts. The first number of the item number has the following meaning:

- 1 Standard components widely available from industrial suppliers (e.g. screws, nuts, washers, etc.).
- 2 Commercial components which, providing that the same quality parameters are adopted, can be purchased anywhere (switches, hoses, etc.).
- 3 Components manufactured by TECNA
- 4 Components manufactured by TECNA
- 5 Electronic circuits manufactured by TECNA.
- 7 Assemblies composed of parts belonging to any or all of the above codes but which for the sake of simplicity are available ready-assembled.

The code number followed by an asterisk warns that the part changes depending on the mains voltage. All spare parts, including standard or commercial ones, are available from TECNA.

ACCESSORIES:

- 3311 Removable key selector for programming lock for TE300.
- 3312 Removable key selector for programming lock for TE450.
- 3313 Holder to mount the control handle on the lower side of the spot gun for items 3321-3322-3323-3324.
- 3314 Holder to mount the control handle on the lower side of the spot gun for items 3327-3328.
- 3315 Holder to mount the control handle on a spot gun side, complete with another handle without control.

ARMS Item 3323:

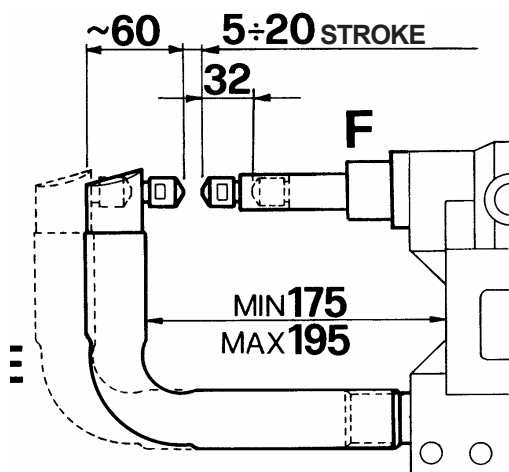

E Art. 4883 Standard lower arm
F Art. 4882 Upper electrode-holder

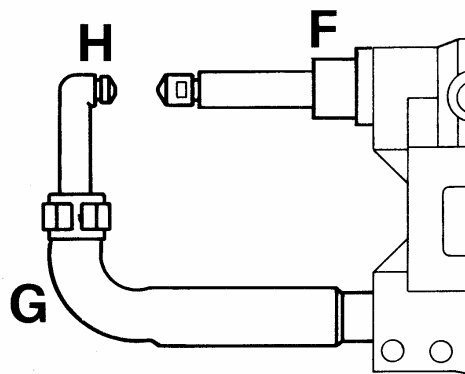

G Art. 4884 Reduced-dimension lower arm
F Art. 4882 Upper electrode-holder

ARMS Item: 3321 - 3322 - 3324 - 3327 - 3328:

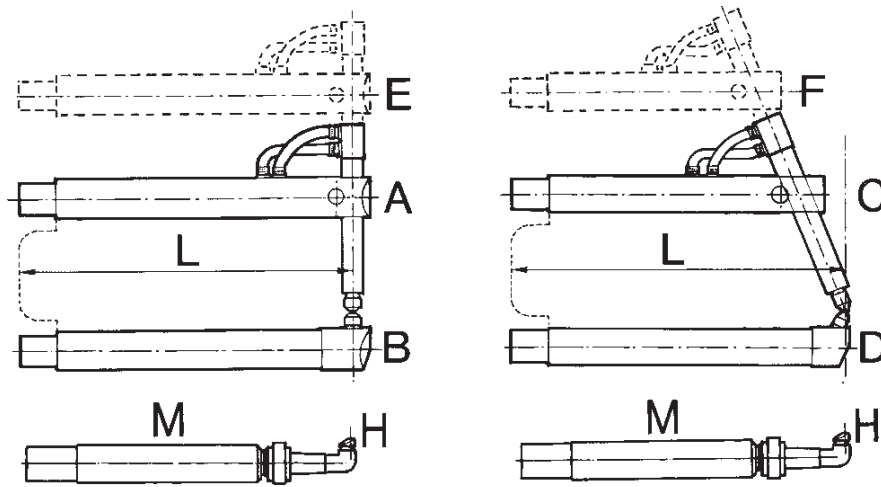





Art. 3321 - 3322	L	mm	190	250	350	508	650	800
	A	Art.	4850	4854	4858	4862	4866	4870
	B	Art.	4852	4856	4860	4864	4868	4872
	C	Art.	4851	4855	4859	4863	4867	4871
	D	Art.	4853	4857	4861	4865	4869	4873
M	Art.	—	4890	4891	4892	4893	—	
Art. 3324	A	Art.	—	4874	4876	4878	4880	—
	B	Art.	—	4856	4860	4864	4868	—
	C	Art.	—	4875	4877	4879	4881	—
	D	Art.	—	4857	4861	4865	4869	—
	M	Art.	—	4890	4891	4892	4893	—

Art. 3327 - 3328	L	mm	—	255	408	610	820	1030
	A	Art.	—	4750	4756	4762	4768	4774
	B	Art.	—	4752	4758	4764	4770	4776
	C	Art.	—	4751	4757	4763	4769	4775
	D	Art.	—	4753	4759	4765	4771	4777
	E	Art.	—	4754	4760	4766	4772	—
F	Art.	—	—	4761	4767	4773	—	

ELECTRODES:

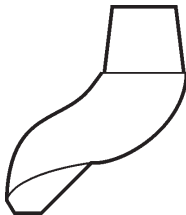
- 3720 - 4720 Straight electrodes, a pair.
- 3721 - 4721 Offset electrodes, a pair.
- 3722 - 4722 Angled offset electrodes, a pair.
- 3723 - 4723 Bent electrodes, a pair.
- 3724 - 4724 Flat electrodes, a pair.
- 3725 - 4725 Swivel electrode 30 mm.
- 4726 Electrode-holder with electrode item 4727, ring nut and fittings.
- 4727 Offset electrode for item 4726.
- 4729 Offset electrode for item 4726.

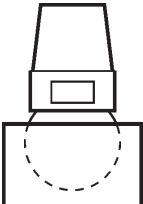
	Art. 3321 - 3322 - 3323 - 3324					
Art.	3720	3721	3722	3723	3724	3725
	Art. 3327 - 3328					
Art.	4720	4721	4722	4723	4724	4725
						

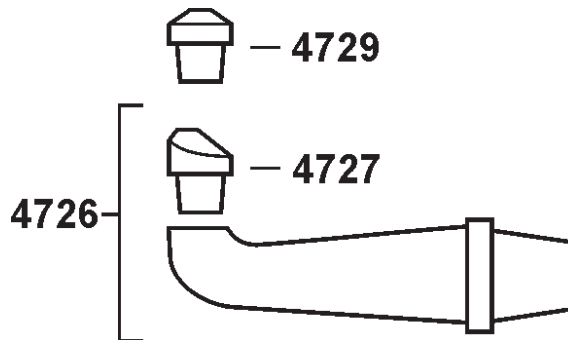

WARNING. On request, the welding unit can be supplied with arms and/or electrodes other than standard. The listed items refer to the standard product.

10.2 WELDING TABLES

In order to facilitate the search for the best welding conditions, we have herewith inserted the following tables stating the approximate adjusting values. Notice that the same weld can be carried out under different working conditions, so much so that the following data are not binding ones.

Low carbon steel spot welding

A welding class

Thickness a mm	Spots minimum distance mm	Minimum overlapping mm	Electrodes		Electrodes force daN	Welding current kA	Welding time cicli	Obtained nugget d1 mm
			D min mm	d max mm				
0.25	6	9.5	9.5	3	90	4	4	3
0.5	9.5	11	9.5	4.5	136	7	5	4
0.75	12.5	11	9.5	4.5	181	8	7	5
1.0	19.5	12.5	13	6.5	225	9.5	8	5.5
1.25	22.5	15	13	6.5	294	10.5	10	6
1.5	27	16	13	6.5	362	12	12	6.5
2.0	35	18	16	8	498	14	18	7.3
2.5	42	19	16	8	590	15.5	22	8.3
2.8	48	21	16	9	725	17.5	24	9
3.2	50	23	22	9	820	19	25	10

B welding class

Thickness a mm	Spots minimum distance mm	Minimum overlapping mm	Electrodes		Electrodes force daN	Welding current kA	Welding time cicli	Obtained nugget d1 mm
			D min mm	d max mm				
0.25	6	9.5	9.5	3	60	3.6	5	3
0.5	9.5	11	9.5	4.5	90	5	8	4
0.75	12.5	11	9.5	4.5	120	6.4	13	5
1.0	19.5	12.5	13	6.5	160	7.5	18	5.5
1.25	22.5	15	13	6.5	200	8.3	20	6
1.5	27	16	13	6.5	240	9	24	6.5
2.0	35	18	16	8	324	10.5	30	7.3
2.5	42	19	16	8	370	11.5	37	8.3
2.8	48	21	16	9	470	12.5	42	9
3.2	50	23	22	9	550	13.5	50	10
4.0	68	32	25	11	640	14.4	75	11.5

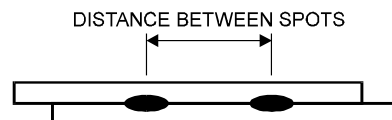
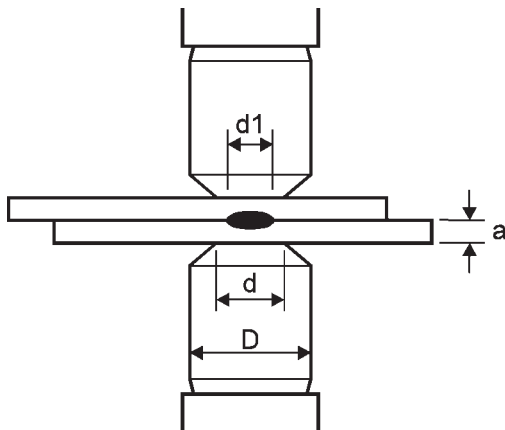

Stainless steel 18/8 spot welding

Thickness a mm	Spots minimum distance mm	Minimum overlapping mm	Electrodes		Electrodes Force daN	Welding current		Welding time cicli	Obtained nugget d1 mm
			D mm	d mm		* kA	** kA		
0.2	5	5	5	2.5	90	2	2	3	1.4
0.3	6	6	6	3	120	2.1	2	3	1.4
0.4	8	6	6	3	150	3	2.5	4	2.2
0.5	8	8	6	4	180	4	3.2	4	2.5
0.6	11	10	10	4	235	5	4.1	4	3
0.8	12	10	10	5	295	6	4.8	4	3.3
1	16	11	10	5	410	7.8	6.3	4	4
1.2	20	12	12.5	6	545	9.5	7.5	7	4.8
1.4	22	14	12.5	6	620	10.3	8.3	9	5.3
1.6	25	16	12.5	6	680	11	9	9	5.6
1.8	28	16	16	6	770	12.3	10	10	6.3
2	32	18	16	7	860	14	11	12	7
2.5	35	20	19	8	1090	15.7	12.7	13	7.2
3	50	22	19	10	1500	18	15.5	17	7.65

* for stainless steel with resistance up to 100 kg/mm2

** for stainless steel with resistance beyond 100 kg/mm2

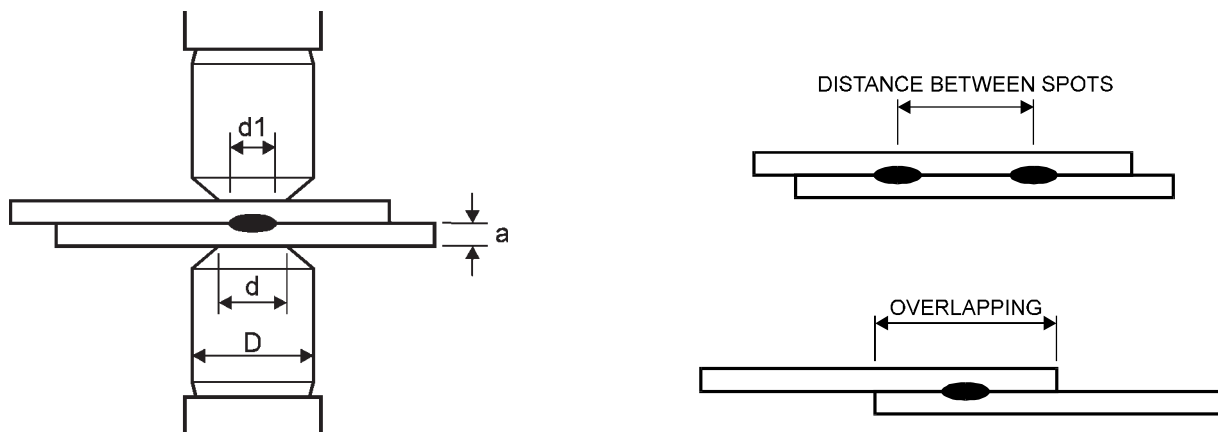

Crossed rods welding of cold drawn low carbon steel

Rod diameter mm	Welding time cicli	Set-down 15%		Set-down 30%	
		Electrodes Force daN	Welding current kA	Electrodes Force daN	Welding current kA
1.6	4	45	0.6	68	0.8
3.2	8	56	1.8	117	2.6
4.8	14	160	3.3	270	5
6.35	19	260	4.5	380	6.7
8	25	415	6.2	650	9.3
10	33	495	7.4	925	11.8
11	42	630	9.3	1300	13.8
12.5	50	765	10.3	1530	15.8

N.B. In the welding of reinforced concrete rods there are cases in which the same parameters can be used to weld different, much higher, diameters.

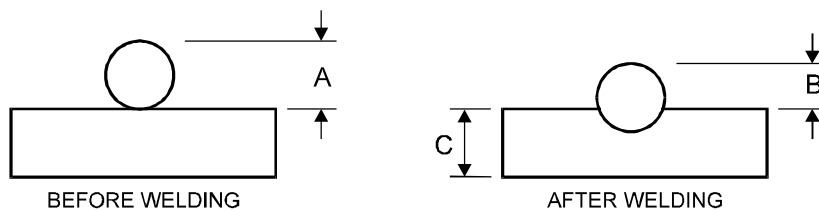

$$\text{SET-DOWN} = \frac{A - B}{A} \times 100$$

10.3 TE300 PRODUCTION FORM FACSIMILE

FIRM DATA

Firm	Department
------	------------

WELDER DATA

Welder model	Number
Welding transformer connecting positioning	

PIECE TO BE WELDED

Description	
Code	Thickness
Material	Coating

WELDING PARAMETER ADJUSTMENT

Foreseen working with: <input type="checkbox"/> FOOT-CONTROL <input type="checkbox"/> TWO-HANDS CONTROL DEVICE	
Cycle foreseen working : <input type="checkbox"/> SINGLE <input type="checkbox"/> REPEAT	
Is during production foreseen the use of double stroke: <input type="checkbox"/> YES <input type="checkbox"/> NO	
Welding pressure adjustment bar	Reached welding current kA
Working stroke adjustment mm	Double stroke adjustment mm

WELDING CONTROL UNIT TE300 PARAMETERS

N°	PARAMETER	PROGRAM N°. 1	PROGRAM N°. 2
2	SQUEEZE		
3	PRE-WELD		
4	CURRENT		
5	COLD TIME		
6	SLOPE		
7	WELDING		
8	CURRENT		
9	IMPULSE NUMBER		
10	HOLD		
11	OFF TIME		
Obtained welding current in kA			

NOTES CONCERNING EITHER ELECTRODES OR WELDING TOOLS

(Electrodes type and diameter, maintenance and electrodes replacement terms, etc.)

Enclose all other useful information (for instance: maintenance and electrodes replacement times, notes on the pieces preparation, etc.)

10.4 TE450 PRODUCTION FORM FACSIMILE

FIRM DATA

Firm	Department
------	------------

WELDER DATA

Welder model	Number	
Used arms type	upper:	lower:
Used electrodes type:	upper:	tip diameter mm
	Lower:	tip diameter mm

PIECE TO BE WELDED

Description	
Code	Thickness
Material	Coating

WELDING PARAMETER ADJUSTMENT

Foreseen working cycle: <input type="checkbox"/> SINGLE <input type="checkbox"/> REPEAT	
Is during production foreseen the use of double stroke: <input type="checkbox"/> YES <input type="checkbox"/> NO	
Welding pressure adjustment bar	obtained welding force daN
Welding stroke adjustment mm	

PARAMETERS ADJUSTMENT ON TE 450 WELDING CONTROL UNIT

N°	PARAMETER	PARAMETER DESCRIPTION	ADJUSTMENT 1 Program n° ____	ADJUSTMENT 2 Program n° ____
A	WORKING MODE	WORKING MODE		
B	CONTROL MODE	CONTROL UNIT MODE		
C	STROKE	DOUBLE STROKE MODE		
1	SQUEEZE 1	SQUEEZE TIME 1		
2	SQUEEZE	SQUEEZE TIME		
3	PRE-WELD	PRE-WELDING TIME		
4	PRE-POWER	PRE-POWER CURRENT		
5	COLD 1	COLD TIME 1		
6	SLOPE UP	SLOPE UP TIME		
7	WELD 1	WELDING TIME		
8	POWER 1 CURRENT 1	WELDING CURRENT		
9	N. IMPULSE	IMPULSES NUMBER		
10	COLD 2	COLD TIME 2		
11	SLOPE DOWN	SLOPE DOWN TIME		
12	COLD 3	COLD TIME 3		
13	POST-WELD	POST-WELDING TIME		
14	POST-POWER	POST-WELDING CURRENT		
15	HOLD TIME	HOLD TIME		
16	OFF TIME	OFF TIME		
17	CURR MIN ANGLE MIN	CURRENT MIN LIMIT MIN LIMIT IN DEGREES		
18	CURR MAX ANGLE MAX	CURRENT MAX LIMIT MAX LIMIT IN DEGREES		
Obtained welding current in Ka				

POSSIBLE STEPPER FUNCTION ADJUSTING PARAMETERS

DELTA INCREMENT	SPOTS COUNTER

Enclose all other useful information (for instance: maintenance and electrodes replacement times, notes on the pieces preparation, etc.)

This page intentionally left blank

This page intentionally left blank

TECNA®

S.p.A. - Via Grieco 25/27 - 40024 Castel S. Pietro Terme - Bologna ITALY
Pho. +39.051.6954400 - Tel. 051.6954410 - Fax +39.051.6954490
E-Mail: sales@tecna.net - vendite@tecna.net